

For Maintenance and Safety

# INDIAN CHIEF OWNER'S MANUAL



2022



## **WARNING**

Read, understand, and follow all of the instructions and safety precautions in this manual and on all product labels.

Failure to follow the safety precautions could result in serious injury or death.



## **WARNING**

Operating, servicing, and maintaining a passenger vehicle or off-road vehicle can expose you to chemicals including engine exhaust, carbon monoxide, phthalates, and lead, which are known to the State of California to cause cancer and birth defects or other reproductive harm. To minimize exposure, avoid breathing exhaust, do not idle the engine except as necessary, service your vehicle in a well-ventilated area and wear gloves or wash your hands frequently when servicing your vehicle.

For more information go to [www.P65Warnings.ca.gov/passenger-vehicle](http://www.P65Warnings.ca.gov/passenger-vehicle).



## **2022 Rider's Manual**

Indian Chief  
Indian Chief Bobber  
Indian Super Chief

Indian Chief Dark Horse  
Indian Chief Bobber Dark Horse  
Indian Super Chief Limited

All information contained within this publication is based on the latest product information available at the time of publication. Product improvements or other changes may result in differences between this manual and the motorcycle. Depictions and/or procedures in this publication are intended for reference use only.

No liability can be accepted for omissions or inaccuracies. Indian Motorcycle Company reserves the right to make changes at any time, without notice and without incurring obligation to make the same or similar changes to motorcycles previously built. Any reprinting or reuse of the depictions and/or procedures contained within, whether whole or in part, is expressly prohibited.

Unless noted, trademarks are the property of Indian Motorcycle International, LLC

Ride Command® is a registered trademark of Polaris Industries, Inc. Pirelli® is a registered trademark of PIRELLI & C. S. P. A. Motorcycle Safety Foundation® is a registered trademark of Motorcycle Safety Foundation. NGK® is a registered trademark of NGK Spark Plug Co., Ltd. BatteryMINDer® is a registered trademark of VDC Electronics, Inc. iPod®, APPLE APP STORE® and Apple CarPlay® are registered trademarks of Apple Inc. iOS® is a registered trademark of CISCO SYSTEMS, INC. Google Play® is a registered trademark of GOOGLE LLC. Bluetooth® is a registered trademark of Bluetooth Sig, Inc. JCASE® is a registered trademark of Littelfuse, Inc.

© 2022 Indian Motorcycle International, LLC

9939939 R01

## CONGRATULATIONS!

---

Congratulations on your purchase of a new INDIAN MOTORCYCLE. You have joined an elite family of motorcycle riders who have acquired a celebrated piece of American history by choosing to own an INDIAN MOTORCYCLE.

Your new motorcycle is the end result of true dedication and craftsmanship by our engineering, design and assembly teams. It was designed and manufactured to meet our goal of providing you with a high quality motorcycle that you can ride trouble-free for many years to come. We hope you will take as much pride in riding your new motorcycle as our team did in building it for you.

We urge you to read this rider's manual thoroughly. It contains information essential to safe riding and proper maintenance of your motorcycle.

Your authorized INDIAN MOTORCYCLE dealer knows your motorcycle best and should be consulted for service and assistance. Skilled technicians using advanced equipment and methods are best qualified to perform all major repairs and service your motorcycle may require.

INDIAN MOTORCYCLE complies with all federal, state and local safety and emission regulations for the area of intended sale.

## CONGRATULATIONS!

---

The following signal words and symbols appear throughout this manual and on your vehicle. Your safety is involved when these words and symbols are used. Become familiar with their meanings before reading the manual.

### DANGER

DANGER indicates a hazardous situation which, if not avoided, **WILL** result in death or serious injury.

### WARNING

WARNING indicates a hazardous situation which, if not avoided, **COULD** result in death or serious injury.

### CAUTION

CAUTION indicates a hazardous situation which, if not avoided, **COULD** result in minor to moderate injury.

### NOTICE

NOTICE provides key information by clarifying instructions.

### IMPORTANT

IMPORTANT provides key reminders during disassembly, assembly, and inspection of components.

---

**Introduction.** . . . . . **7**

**Safety.** . . . . . **9**

    Reporting Safety Defects . . . . . 19

**Instruments, Features and Controls** . . . . . **21**

**Ride Command (If Equipped)** . . . . . **45**

**Pre-Ride Inspections** . . . . . **61**

**Operation.** . . . . . **71**

**Maintenance** . . . . . **83**

**Cleaning and Storage** . . . . . **161**

**Specifications.** . . . . . **167**

**Warranty** . . . . . **177**

**Maintenance Log** . . . . . **189**





---

# INTRODUCTION

## IDENTIFICATION NUMBER RECORDS

Record important identification numbers below:

|  |  |
|--|--|
| <b>Vehicle Identification Number (VIN)</b> |  |
| <b>Engine Identification Number</b>        |  |
| <b>Master PIN</b>                          |  |
| <b>Rider PIN</b>                           |  |
| <b>Key Fob #1 Serial Number</b>            |  |
| <b>Key Fob #2 Serial Number (optional)</b> |  |

## INTRODUCTION

---

### SERVICE AND WARRANTY INFORMATION

Some procedures are beyond the scope of this manual. See your dealer to purchase an *INDIAN MOTORCYCLE Service Manual*. Some procedures provided in the service manual require specialized knowledge, equipment, and training. Be sure you have the required technical skills and tools that are needed before you attempt ANY service on your motorcycle. Please contact your authorized dealer before attempting any service work that is beyond your level of technical knowledge or experience, or if the work requires specialized equipment.

### OPERATING MOTORCYCLE ABROAD

If you plan to operate your motorcycle in countries abroad:

- Service facilities or replacement parts may not be readily available.
- Unleaded gasoline may not be available. The use of leaded fuels will cause engine damage, damage to your emissions systems and voiding of your warranty.
- Gasoline may have a considerably lower octane rating. Improper fuel can cause engine damage.

### ENGINE IDENTIFICATION NUMBER

The engine number ① is stamped into the right crankcase beneath the balance shaft cover. The engine number is positioned behind the right floorboard with the engine installed in the frame. Record the number in the space provided on page 7.

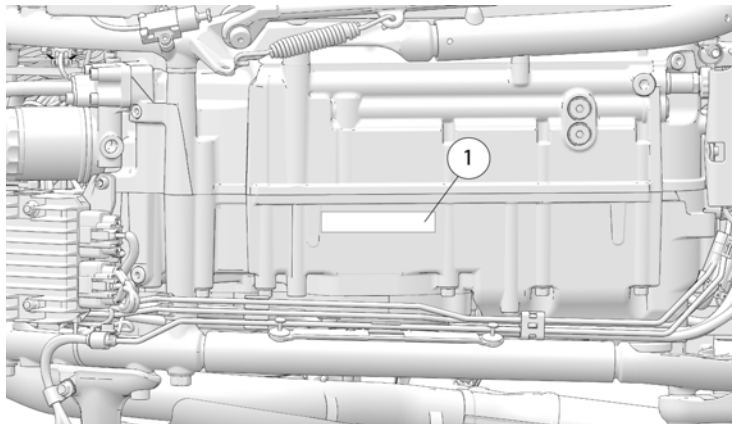

## SAFETY ABOUT THE RIDER'S MANUAL

### WARNING

Failure to follow all recommended precautions and procedures could result in serious injury or death. Always heed all safety precautions and follow all operation, inspection and maintenance procedures outlined in this manual.

All references to RIGHT, LEFT, FRONT or REAR are from the operator's perspective when seated in a normal riding position. If you have questions about the operation or maintenance of your motorcycle after you've read this manual, please see your authorized dealer. To locate the nearest authorized INDIAN MOTORCYCLE dealer, visit the INDIAN MOTORCYCLE web site at [www.indianmotorcycle.com](http://www.indianmotorcycle.com).

Carefully read and understand the information found in the *Safety* section beginning on this page. To keep your motorcycle in peak condition on the road or in storage, understand and follow the procedures outlined in the *Maintenance* section beginning on page 83.

Bring the manual along when you ride. Following the precautions and procedures in the manual will add to your enjoyment and help keep you safe. If you lose or damage this manual, please purchase a new one through any authorized INDIAN MOTORCYCLE dealer. This rider's manual should be considered part of the motorcycle and should remain with the motorcycle when ownership changes.

## SAFE RIDING PRACTICES

### WARNING

Improper use of a motorcycle can result in serious injury or death to you, your passenger and others. To minimize the risk of injury, read and understand the information contained in this section before operating the motorcycle. This section contains safety information specific to the INDIAN MOTORCYCLE, as well as information about general motorcycle safety. Anyone who rides the motorcycle (operators and passengers) must follow these safety precautions.

## MOTORCYCLING HAS INHERENT RISKS

You can minimize those risks, but you can't eliminate them completely. Even if you're an experienced motorcycle operator or passenger, read all of the safety information in this manual before operating the motorcycle.

- Take a rider education course from the Motorcycle Safety Foundation® or another qualified instructor. The course will help you develop or refresh your expertise in safe riding habits through instruction and riding. For information on Motorcycle Safety Foundation® rider education courses in your area, call 1-800-446-9227 or visit [www.msf-usa.org](http://www.msf-usa.org).
- Read, understand, and follow all information in this manual.
- Observe all maintenance requirements specified in this manual. See the INDIAN MOTORCYCLE Service Manual or an authorized INDIAN MOTORCYCLE dealer.

### DESIGN CHARACTERISTICS AFFECT HOW YOU SHOULD RIDE THE MOTORCYCLE

- The motorcycle is designed for on-road use with one rider (and one passenger if the motorcycle is equipped with a passenger seat). *Never exceed the GVWR or the GAWR.* Refer to the *Specifications* section, or the Manufacturing Information/VIN label on the motorcycle frame for model-specific information.
- Riding off-road, riding with more than one passenger, or carrying weight exceeding the maximum weight rating can make handling difficult, which could cause loss of control.
- During the first 500 miles (800 km) of operation, follow all break-in procedures as outlined on page 71. Failure to do so can result in serious engine damage.
- If your motorcycle is equipped with saddlebags, a windshield or a passenger backrest, be prepared to reduce operating speed to maintain stability.

### FOLLOW THESE GENERAL SAFE RIDING PRACTICES

- Before each ride, perform the Pre-Ride Inspections. Failure to do so may result in damage to the motorcycle or an accident.
- Until you're thoroughly familiar with the motorcycle and all of its controls, practice riding where there is little or no traffic. Practice riding at a moderate speed on various road surfaces and in different weather conditions.
- Know your skills and limits, and ride within them.
- Allow only licensed, experienced operators to ride your motorcycle, and then only after they have become familiar with its controls and operation. Make sure all riders read and understand this rider's manual before riding.
- Do not ride when you're fatigued, ill or under the influence of alcohol, prescription drugs, over-the-counter drugs or any other drugs. Fatigue, illness, alcohol and drugs can cause drowsiness, loss of coordination and loss of balance. They can also affect your awareness and judgment.
- If your motorcycle operates abnormally, correct the problem immediately. See the *INDIAN MOTORCYCLE Service Manual* or an authorized INDIAN MOTORCYCLE dealer.
- Ride defensively, as if you are invisible to other motorists, even in broad daylight. *A motorist's failure to see or recognize a motorcycle is the leading cause of automobile/motorcycle accidents.* Ride where you're clearly visible to other motorists, and observe their behavior carefully.
- Be especially cautious at intersections, as these are the most likely places for an accident.
- To prevent loss of control, keep your hands on the handlebars and your feet on the footrests.
- Be aware that a highway bar is not designed to protect the rider from injury in a collision.
- Obey the speed limit and adjust your speed and riding technique based on road, weather and traffic conditions. As you travel faster, the influence of all other conditions increases, which can affect the motorcycle's stability and increase the possibility of losing control.

- Do not move or operate the motorcycle with the steering locked (if equipped), as the severely restricted steering could result in loss of control.
  - Reduce speed when:
    - The road has potholes or is otherwise rough or uneven.
    - The road contains sand, dirt, gravel or other loose substances.
    - The road is wet, icy or oily.
    - The road contains painted surfaces, manhole covers, metal grating, railway crossings or other slippery surfaces.
    - The weather is windy, rainy or otherwise causing slippery or rapidly changing conditions.
    - Traffic is heavy, congested, not allowing sufficient space between vehicles or otherwise not flowing smoothly.
    - You are being passed in either direction by a large vehicle that may produce a wind blast in its wake.
  - When approaching a curve, choose a speed and lean angle that allows you to pass through the curve in your own lane without applying the brakes. Excessive speed, improper lean angle or braking in a curve can cause loss of control.
  - Ground clearance is reduced when the motorcycle leans. Do not allow components to contact the road surface when leaning the motorcycle in a curve, as this could cause loss of control.
  - Do not tow a trailer. Towing a trailer can make the motorcycle hard to handle.
  - Retract the sidestand fully before riding. If the sidestand is not fully retracted, it could contact the road surface and cause loss of control.
  - To maximize braking effectiveness, *use the front and rear brakes together*. Be aware of the following braking facts and practices:
    - The rear brake provides 40% of the motorcycle's stopping power, at most. Use the front and rear brakes together.
    - To avoid skidding, apply the brakes gradually when the road is wet or rough, or contains loose or other slippery substances.
    - If possible, avoid applying the brakes while making a turn. Motorcycle tires have less traction during turns, so braking will increase the possibility of skidding. Bring the motorcycle to the upright position before applying the brakes.
    - With new pads and rotors, allow up to 250 miles (500 km) of operation in urban driving conditions (not highway cruising) to allow pads to mate with new rotors. Brakes should be used frequently. During this time brake performance will be less effective. Avoid using brakes harshly unless in an emergency. Brake efficiency will gradually increase during this seating period.
  - Hot engine and exhaust components can cause burns to skin and can ignite a fire if exposed to flammable materials. Always park the motorcycle clear of flammable materials and where people are not likely to contact hot components.
-

### PROTECTIVE APPAREL

#### IMPORTANT

Wear protective apparel to decrease the risk of injury and increase riding comfort.

- Always wear a helmet that meets or exceeds established safety standards. Approved helmets in the USA and Canada bear a U.S. Department of Transportation (DOT) label. Approved helmets in Europe, Asia and Oceania bear the ECE 22.05 label. The ECE mark consists of a circle surrounding the letter E, followed by the distinguishing number of the country which has granted approval. The approval number and serial number will also be displayed on the label. Laws in some areas *require* that you wear an approved helmet. Head injuries are the leading cause of fatalities in accidents involving motorcycles. Statistics prove that an approved helmet is the most effective protection in preventing or reducing head injuries. The helmet should fit snugly, be securely fastened, have no obvious defects, and have not previously been involved in an accident/crash.
- Wear eye protection to protect eyes from wind or airborne particles and objects. Wearing a face shield can help protect your face in an accident/crash and protect face from wind or airborne particles or objects. Laws in some areas *require* that you wear eye protection. We recommend that you wear approved Personal Protective Equipment (PPE) bearing markings such as VESC 8, V-8, Z87.1, or CE. Make sure protective eyewear is kept clean.

- All riders should wear bright or light-colored and/or reflective clothing to improve visibility to other motorists. *A motorist's failure to see or recognize a motorcycle is the leading cause of automobile/motorcycle accidents.*
- Wear gloves, a jacket, heavy boots and long pants to prevent or reduce injury from abrasions, lacerations or burns should the motorcycle fall. Wear boots with low heels, as high heels can catch on pedals or footrests. The combination of boots and pants should completely cover legs, ankles and feet, protecting skin from engine and exhaust system heat.
- Do not wear loose, flowing clothing or long boot laces, as they can catch on handlebars, levers or footrests, or they can become entangled in the wheels, causing loss of control and serious injury.

### CARRYING A PASSENGER



**WARNING**

Do not carry a passenger unless the motorcycle is equipped with passenger seat and passenger footrests.

---

## CARRYING CARGO

Use the following guidelines when attaching cargo or accessories to the motorcycle. Where applicable, these guidelines also refer to the contents of any accessories.

- Keep cargo and accessory weight to a minimum, and keep items as close to the motorcycle as possible to minimize a change in the motorcycle's center of gravity. Changing the center of gravity can cause loss of stability and handling and could cause loss of control.
  - Adjust ride height as needed. See page 116.
  - Do not exceed the GROSS VEHICLE WEIGHT RATING (GVWR) or the GROSS AXLE WEIGHT RATING (GAWR) for your motorcycle.
  - Distribute weight evenly on both sides of the motorcycle. Maintain even weight distribution by checking accessories and cargo to make sure they're securely attached to the motorcycle before riding and whenever you take a break from riding. Uneven weight distribution or sudden shifting of accessories or cargo while you're riding may cause difficult handling, loss of control and driving hazards for other motorists (if cargo falls from the motorcycle).
  - For riding comfort and to ensure proper ground clearance, adjust rear shock air pressure (if equipped) as specified on the label located under the left side cover. See page 116.
- Do not attach large or heavy cargo such as sleeping bags, duffel bags or tents to the handlebars, front fork area or front fender. Cargo or accessories placed in these areas can cause instability (due to improper weight distribution or aerodynamic changes) and could cause loss of control. Such items can also block air flow to the engine and cause overheating that can damage the engine.
  - Do not exceed the maximum cargo weight limit of any accessory (see accessory instructions and labels). Do not attach cargo to an accessory not designed for that purpose. Either circumstance could result in an accessory failure that could cause loss of control.
  - Always obey posted speed limits.
  - Do not attach anything to the motorcycle unless specifically designed for that purpose by INDIAN MOTORCYCLE.

## SADDLEBAGS, TRUNK AND OTHER STORAGE

Whenever operating a motorcycle equipped with cargo storage features such as saddlebags, a trunk, racks, glove boxes or other storage compartments:

- Never ride at excessive speeds. Storage features and cargo, combined with the lifting or buffeting effects of wind, can make a motorcycle unstable and cause loss of control.
- Distribute weight evenly on each side of the motorcycle.
- Do not exceed the individual weight limit of any saddlebag, trunk or other storage compartment. Refer to the storage capacity label located on or near the storage feature.

## SAFETY

---

- NEVER EXCEED the GROSS VEHICLE WEIGHT RATING (GVWR) or the GROSS AXLE WEIGHT RATING (GAWR), regardless of whether or not any storage feature is loaded to capacity. Exceeding the weight rating can reduce stability and handling and cause loss of control.
- Adjust ride height as needed. See page 116.

## USE OF ACCESSORIES

Because INDIAN MOTORCYCLE cannot test and make specific recommendations concerning every accessory or combination of accessories sold, the operator is responsible for determining that the motorcycle can be safely operated with any accessories or additional weight. Use the following guidelines when choosing and installing accessories:

- Do not install accessories that impair operator visibility or the stability, handling or operation of the motorcycle. Before installing an accessory, be sure that it does not:
  - reduce ground clearance when the motorcycle is either leaned or in a vertical position;
  - limit suspension or steering travel or your ability to operate controls;
  - displace you from your normal riding position;
  - obscure lights or reflectors.
- Bulky, heavy or large accessories can cause instability (due to the lifting or buffeting effects of wind) and loss of control.

- Do not install electrical accessories that exceed the capacity of the motorcycle's electrical system. Never install higher wattage light bulbs than those supplied as original equipment. An electrical failure could result and cause hazardous loss of engine power or lights, or damage to the electrical system.
- Use only genuine INDIAN MOTORCYCLE accessories designed for your model.
- Do not exceed the gross vehicle weight rating (GVWR) for your motorcycle.
- Adjust ride height as needed.



## MODIFICATIONS

Modifying the motorcycle by removing any equipment or by adding equipment not approved by the manufacturer may void your warranty. Some modifications may not be legal in your area of operation. If in doubt, contact your authorized INDIAN MOTORCYCLE dealer.

### CAUTION

Modifications could make the motorcycle unsafe to ride and could result in serious injury to operator or passenger, as well as damage to the motorcycle.

## PARKING THE MOTORCYCLE

When leaving the motorcycle unattended, turn the engine off. If your motorcycle is equipped with a keyed ignition, remove the ignition key to prevent unauthorized use.

### NOTICE

Do not store your key fob near the motorcycle.

Park the motorcycle where people are not likely to touch the hot engine or exhaust system or place combustible materials near these hot areas. Do not park near a flammable source such as a kerosene heater or an open flame, where hot components could ignite combustible materials.

Park the motorcycle on a firm, level surface. Sloped or soft surfaces may not support the motorcycle. If you must park on a slope or soft surface, follow the precautions outlined on page 80.

## ANTI-LOCK BRAKE SYSTEM RESPONSE (IF EQUIPPED)

When the anti-lock brakes engage during a braking event, the rider will feel pulsing at the brake levers. *Continue to apply steady pressure to the brakes for the best stopping performance.*

## FUEL AND EXHAUST SAFETY

Always heed these fuel safety warnings when refueling or servicing the fuel system.

### WARNING

Gasoline is highly flammable and explosive under certain conditions.

- Always exercise extreme caution whenever handling gasoline.
- Always turn off the engine before refueling.
- Always refuel outdoors or in a well-ventilated area.
- Open the fuel cap slowly. Do not overfill the tank. Do not fill the tank neck.
- Do not smoke or allow open flames or sparks in or near the area where refueling is performed or where gasoline is stored.

## SAFETY

### WARNING

Gasoline and gasoline vapors are poisonous and can cause serious injury.

- Do not swallow gasoline, inhale gasoline vapors, or spill gasoline. If you swallow gasoline, inhale more than a few breaths of gasoline vapor, or get gasoline in your eyes, see a physician immediately.
- If gasoline spills on your skin or clothing, immediately wash it off with soap and water and change clothing.
- Exhaust gases contain carbon monoxide, a colorless, odorless gas that can cause loss of consciousness or death in a short time.
- Never start the engine or let it run in an enclosed area.
- Never inhale exhaust gases.

## SAFETY MAINTENANCE

### WARNING

Failure to perform safety maintenance as recommended can result in difficult handling and loss of control, which could result in serious injury or death. Always perform the safety maintenance procedures as recommended in this manual. Perform maintenance and repairs promptly. See the INDIAN MOTORCYCLE Service Manual or an authorized INDIAN MOTORCYCLE dealer or other qualified dealer.

- Before each ride, perform the *Pre-Ride Inspections*.
- Perform all periodic maintenance at the recommended intervals outlined in the *Periodic Maintenance* section.
- Always maintain proper tire pressure, tread condition and wheel and tire balance. Inspect tires regularly and replace worn or damaged tires promptly. Use only approved replacement tires. See the *Specifications* section.
- Always ensure proper steering head bearing adjustment. Regularly inspect the rear shock absorber and the front forks for fluid leaks or damage. Make any necessary repairs promptly. See page 118.
- Clean the motorcycle thoroughly to reveal items in need of repair.
- Fasteners must meet original specifications for quality, finish and type to ensure safety. Use only genuine INDIAN MOTORCYCLE replacement parts, and ensure that all fasteners are tightened to the proper torque.

## TRANSPORTING THE MOTORCYCLE

If you must transport the motorcycle:

- Use a truck or trailer. Do not tow the motorcycle with another vehicle, as towing will impair the motorcycle's steering and handling.
- Position and restrain the motorcycle in an upright position.
- Place tiedowns as wide apart as possible on the trailer or vehicle for best stability.
- Do not restrain the motorcycle using the handlebars.

- Loop tiedown straps (from the front) up and over the lower triple clamp, using care to not interfere with wiring and brake lines. Place tiedowns as wide apart as possible on the truck or trailer bed for best stability.
- Do not engage the side stand during truck or trailer transportation.
- For added security, additional straps may be routed around the frame between the fuel tank and the seat. Use care to not place the straps over wiring harnesses or evap lines.

This device contains license-exempt transmitter(s)/receiver(s) that comply with Innovation, Science and Economic Development Canada's license-exempt RSS(s). Operation is subject to the following two conditions:

1. This device may not cause interference.
2. This device must accept any interference, including interference that may cause undesired operation of the device.

## **ELECTROMAGNETIC INTERFERENCE**

This vehicle complies with UN ECE Regulation 10 requirements and Canadian ICES-002.

## **RADIO COMPLIANCE STATEMENTS**

*The following statements apply to radio components offered with this vehicle. These include but may not be limited to the touchscreen display.*

This device complies with part 15 of the FCC Rules. Operation is subject to the following two conditions: (1) This device may not cause harmful interference, and (2) this device must accept any interference received, including interference that may cause undesired operation.

This device complies with FCC RF radiation exposure limits for general population.

## SAFETY

### CAUTION

This equipment complies with part 15 of the Federal Communications Commission (FCC) rules.

These requirements are intended to provide reasonable protection against harmful interference in a residential installation. This equipment generates, uses and can radiate radio frequency energy and, if not installed and used in accordance with the instructions, may cause harmful interference to radio communications. However, there is no guarantee that interference will not occur in a particular installation.

If this equipment does cause harmful interference to radio or television reception, which can be determined by turning the equipment off and on, the user is encouraged to try to correct the interference by one or more of the following measures:

- Reorient or relocate the receiving antenna.
- Increase the separation between the equipment and receiver.
- Connect the equipment into an outlet on a circuit different from that to which the receiver is connected.
- Consult the dealer or an experienced radio/TV technician for help.

Changes or modifications to this equipment not expressly approved by the party responsible for compliance could void the user's authority to operate the equipment.

This vehicle contains the following radio equipment or components that contain radio equipment:

| COMPONENT  | COMPONENT ID | MANUFACTURER            |
|--|--------------|-------------------------|
| Key Fob  | 4017768      | Marquardt Switch, Inc.  |
| Key Fob (Japan Only)   | 4019469      | Marquardt Switch, Inc.  |
| Tire Pressure Monitoring System (TPMS) Sensor (Accessory Only) | 4019660      | Schrader                |
| Display (3" Ride Command Display)                              | RC-3R        | Polaris Industries Inc. |
| Wireless Control Module (WCM)                                  | 2415815      | Marquardt Switch, Inc.  |
| Wireless Control Module (WCM) Japan Only                       | 2415607      | Marquardt Switch, Inc.  |

Hereby, INDIAN MOTORCYCLE declares that the above radio equipment is in compliance with EU Directive 2014/53/EU.

The full text of the EU declaration of conformity is available at the following internet address:

<https://www.polaris.com/en-us/radio-conformity/>

## GROSS VEHICLE WEIGHT RATING (GVWR)



Exceeding the gross vehicle weight rating of your motorcycle can reduce stability and handling and could cause loss of control. NEVER exceed the GVWR of your motorcycle.

The *maximum load capacity* of your motorcycle is the maximum weight you may add to your motorcycle *without exceeding the GVWR*. This capacity is determined by calculating the difference between your motorcycle's GVWR and wet weight.

Refer to the *Specifications* section of this manual or the Manufacturing Information/VIN label on the motorcycle frame for model-specific information.

When determining the weight you will be adding to your motorcycle, and to ensure you do not exceed the maximum load capacity, include the following:

- Operator body weight
- Passenger body weight
- Weight of all rider's apparel and items in or on apparel
- Weight of any post-production accessories and their contents
- Weight of any additional cargo on the motorcycle

## REPORTING SAFETY DEFECTS

If you believe that your vehicle has a defect that could result in a crash or cause injury or death, you should immediately inform the National Highway Traffic Safety Administration (NHTSA) in addition to notifying INDIAN MOTORCYCLE in writing.

If NHTSA receives similar complaints, it may open an investigation, and if it finds that a safety defect exists in a group of vehicles, it may order a recall and remedy campaign. However, NHTSA cannot become involved in individual problems between you, your INDIAN MOTORCYCLE dealer or INDIAN MOTORCYCLE.

To contact NHTSA, or obtain other information about motor vehicle safety, you may either call the Vehicle Safety Hotline toll-free at 1-888-327-4236 (TTY: 1-800-424-9153), visit the NHTSA web site at [www.safercar.gov](http://www.safercar.gov), or write to:

ADMINISTRATOR, NHTSA  
1200 New Jersey Avenue, SE  
West Building  
Washington, DC 20590

## REPORTING SAFETY DEFECTS (CANADA)

To report a safety defect to Transport Canada, you may either fill out an online defect complaint form at their website (English: <http://www.tc.gc.ca/recalls>, French: <http://www.tc.gc.ca/rappels>) or contact their Defect Investigations and Recalls Division by calling toll-free 1-800-333-0510 (Canada) or 819-994-3328 (Ottawa-Gatineau area / International).

## SAFETY AND INFORMATION LABELS

*NOTICE*

Models shown for reference only. Safety label locations may vary depending on model.

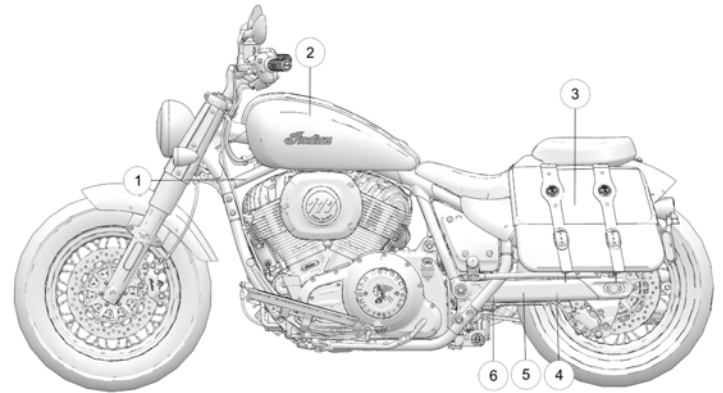
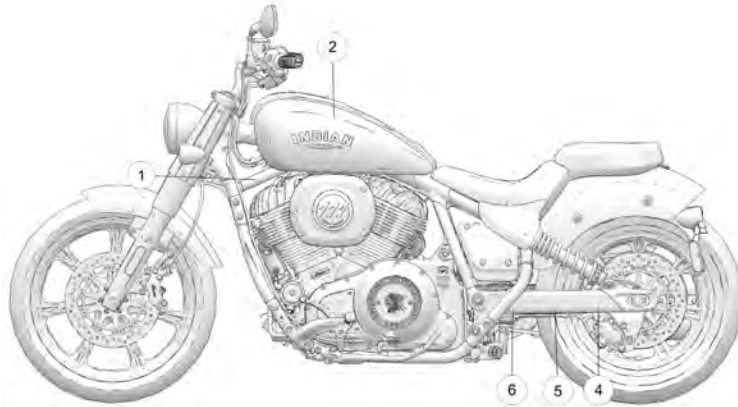

- ① Vehicle Identification Number (VIN) (side of steering head)
- ② Operator Warning/Fuel Recommendation
- ③ Saddlebag / Cargo Warning

- ④ Evaporative Emission Information (EVAP)
- ⑤ Vehicle Emission Control Information (VECI)
- ⑥ Noise Emission Control Information (NECI)

## INSTRUMENTS, FEATURES AND CONTROLS

### CONSOLE

- ① Clutch Lever
- ② Left Control
- ③ Multifunction Gauge
- ④ Fuel Cap
- ⑤ Front Brake Master Cylinder
- ⑥ Right Control
- ⑦ Throttle Grip
- ⑧ Front Brake Lever

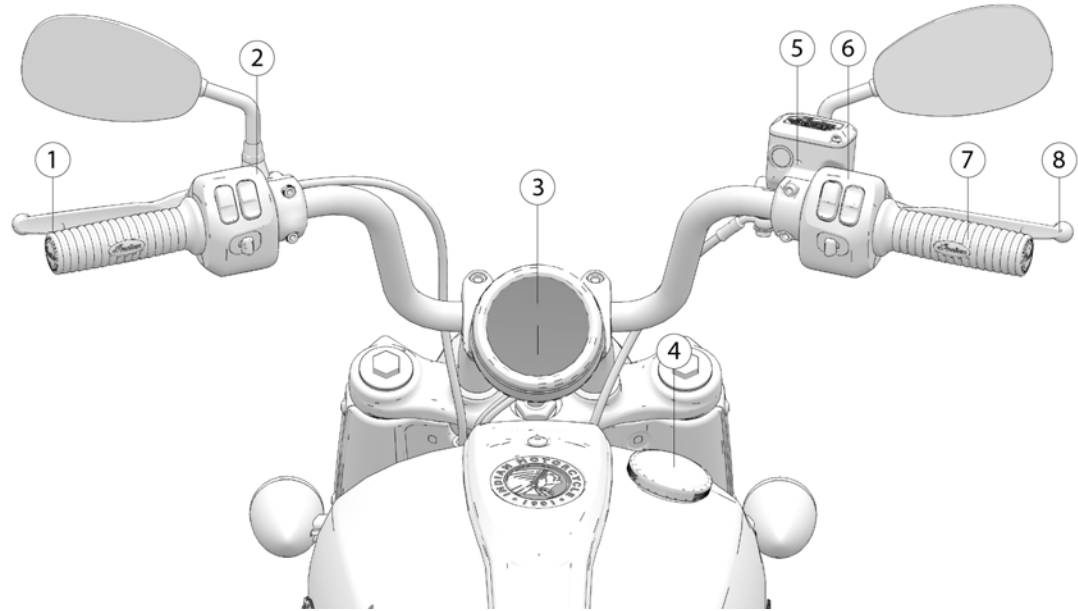

## SWITCH LOCATIONS

### LEFT CONTROL

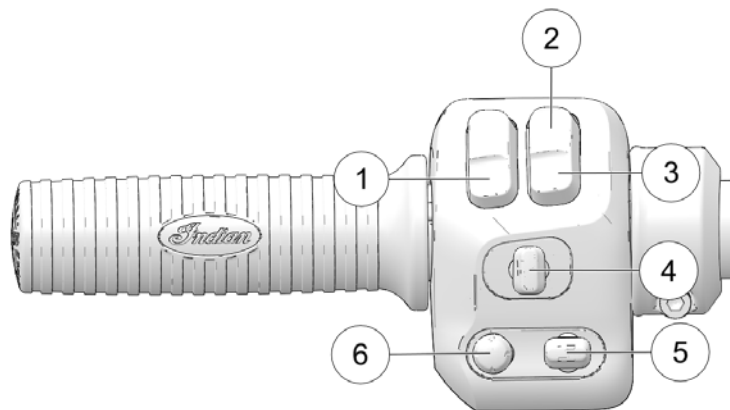

- ① Horn
- ② Hi Beam
- ③ Low Beam/ Flash to Pass
- ④ Turn Signal/Hazard Signal
- ⑤ Screen List Select (if equipped)
- ⑥ Audio Control Switch (if equipped)

### RIGHT CONTROL

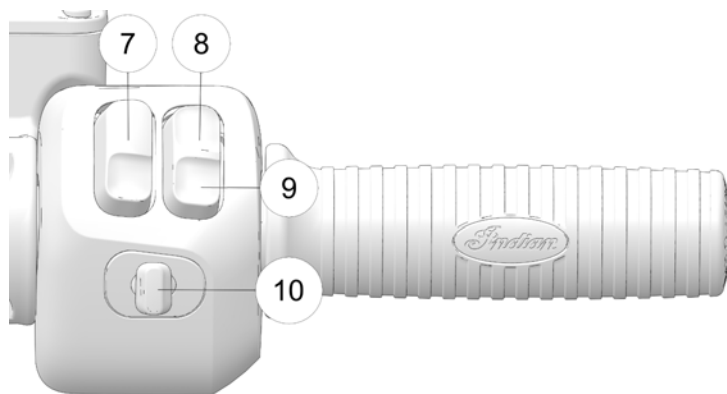

- ⑦ Power Switch
- ⑧ Engine Stop Switch
- ⑨ Engine Start/Run Switch
- ⑩ Cruise Control Switch



## TOGGLE SWITCHES

All models are equipped with toggle switches on the front side of the left ① and right handlebar controls.

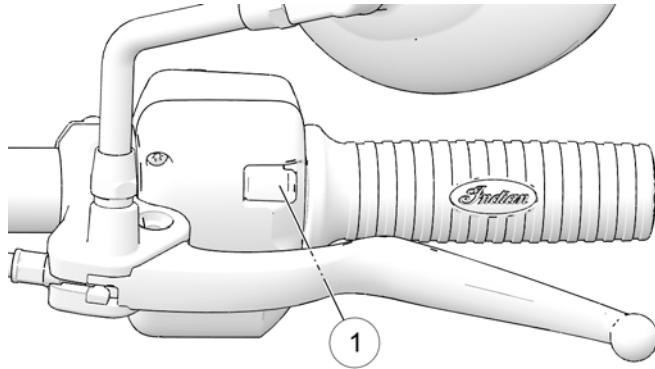







The power switch must be ON for the toggle switches to function. Use the right-hand switch to navigate through menus or accept dialog boxes on the Ride Command display. Use the left-hand switch to back out of menus, decline dialog boxes, hang up phone calls, and toggle through display screens.

## SWITCH SYMBOLS

| SYMBOL | SWITCH                                   | DESCRIPTION  |
|--------|--|--|
|        | Horn Switch                              | Press the horn switch to sound the horn.   |
|        | High Headlight Beam Switch               | The high headlight beam switch activates the high headlight beam. See page 26.   |
|        | Low Headlight Beam Switch                | The low headlight beam switch activates the low headlight beam. Press down momentarily to activate Flash to Pass. See page 26.   |
|        | Turn Signal Switch                       | Move the switch to the left to activate the left turn signals. Move the switch to the right to activate the right turn signals. A signal will deactivate automatically when speed or distance reach predetermined levels. To cancel a signal manually, move the switch to the center position and push it inward. <i>Momentary Feature: Move the turn signal switch left or right and hold it in that position for at least one second. The momentary feature will activate and the signal will then cancel when the switch is released.</i> |
|        | Emergency Flasher Switch (Hazard Switch) | The hazard switch activates and cancels the emergency flashers. See page 27.   |

## INSTRUMENTS, FEATURES AND CONTROLS

| SYMBOL   | SWITCH                    | DESCRIPTION  |
|--|---------------------------|--|
|  | Screen List Select Switch | The Screen List Select Switch (if equipped) is used to navigate through rider screens.   |
|  | Audio Control Switch      | The Audio Control Switch allows users to control the audio system features from the left control block. See page 27.                           |
|  | Stop Switch               | Press the bottom of the switch (RUN) to allow the engine to start and run. Press the top of the switch (STOP) to stop the engine. See page 25. |
|  | Starter Switch            | Use the starter switch to start the engine. The engine stop/run switch must be in the RUN position. See page 25.                               |
|  | Power Switch              | Press and release the power switch to enable or disable all electrical power to the vehicle. See page 24.                                      |
|  | Left-Hand Trigger Switch  | Use the left-hand switch to back out of menus, decline dialog boxes, hang up phone calls, and toggle through display screens. See page 23.     |
|  | Right-Hand Trigger Switch | Use the right-hand switch to navigate through menus or accept dialog boxes on Ride Command display.  |

## SWITCHES

### POWER SWITCH

The power switch is located on the right control ①. Press and release the power switch to enable or disable all electrical power to the vehicle.

To disable all electrical power if the motorcycle is moving and the engine is running, press and hold the power switch for more than three seconds.



#### NOTICE

The headlights and any accessories plugged into power ports will remain on until the power switch is turned off.

**NOTICE**

To save battery power, the vehicle will automatically power off after five minutes of inactivity. Automatic power down can be overridden on bikes equipped with an INDIAN MOTORCYCLE Ride Command display through the Vehicle Settings menu.

**ENGINE STOP/RUN SWITCH**

Use the engine stop/run switch to turn the engine off quickly.

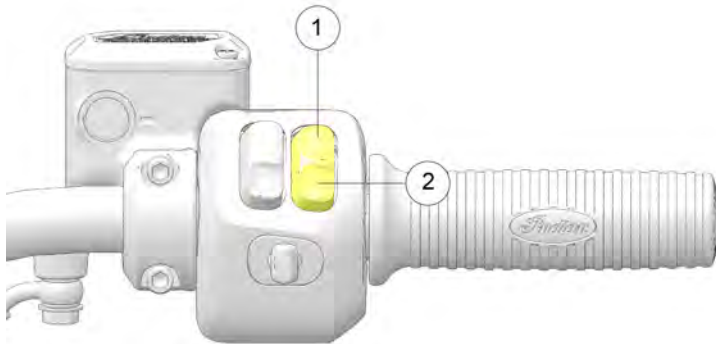

Press the top of the switch (STOP) ① to interrupt the circuits and stop the engine. The engine should not start or run when the switch is in the STOP position.

Press the bottom of the switch (RUN) ② to complete the circuits and allow the engine to start and run. Press and Release the bottom switch (RUN) ② to start the engine.

**CRUISE CONTROL SWITCH**

Cruise control can be activated and adjusted from the right control using the Cruise Control Switch ①. For more information about Cruise Control, see page 79.

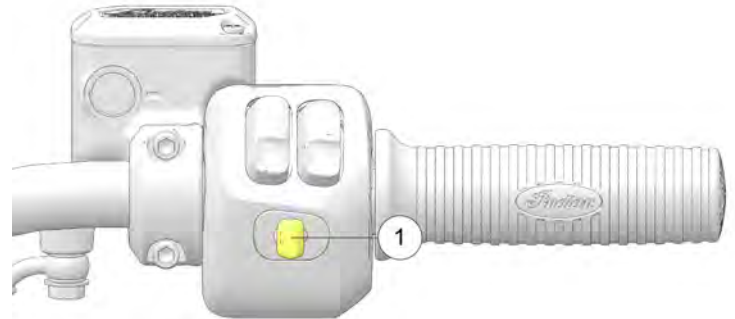

| Toggle Position | Function       |
|-----------------|----------------|
| Left            | Set/Decelerate |

## INSTRUMENTS, FEATURES AND CONTROLS

|        |                   |
|--------|-------------------|
| Center | Off/On            |
| Right  | Resume/Accelerate |

### HIGH/LOW HEADLIGHT BEAM SWITCH

The headlights automatically come on when the engine is started. See page 37.

The high/low headlight beam switch toggles the headlight between high beam and low beam. To activate the high beam, press the upper portion of the switch. To activate the low beam, press the lower portion of the switch. To momentarily flash headlights (Flash to Pass), press and hold the lower portion of the switch.

### HORN SWITCH

Press the horn switch ① to sound the horn.

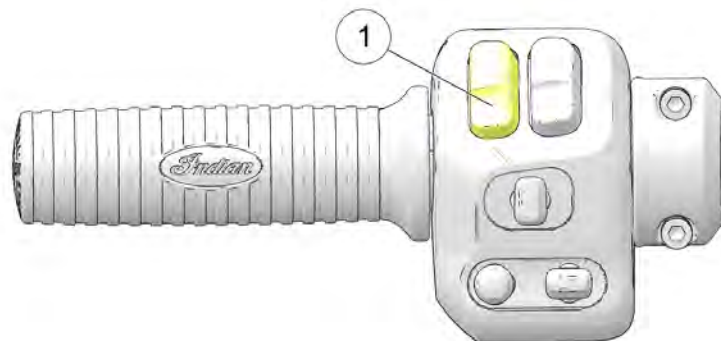

## HAZARD SWITCH

The power switch must be ON to activate the flashers, but once activated, the flashers will continue to flash when the power switch is turned off. When the flashers are active, all four turn signals flash.

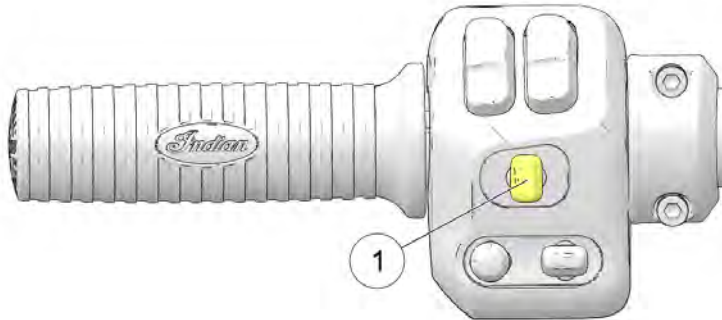

To activate the hazard switch, press on the center of the turn signal switch ①.

- Press and hold the switch to activate the flashers.
- Press the switch again to cancel the flashers.

## AUDIO CONTROL SWITCH (IF EQUIPPED)

The Audio Control Switch ① allows users to control the audio system features from the left control block.

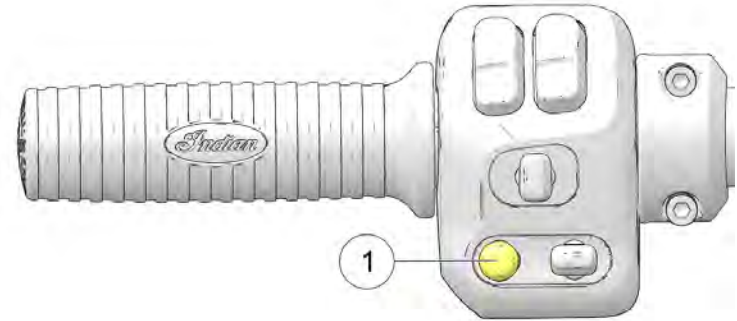

## VOLUME

To increase volume, press up on the audio control switch. To decrease the volume, press down on the audio control switch. To mute the volume, push in on the audio control switch.

### NOTICE

When using a Bluetooth® audio device, pushing down on the audio control switch will pause the audio. To resume, press down on the audio control switch again.

## INSTRUMENTS, FEATURES AND CONTROLS

---

### **PERSONAL AUDIO**

When audio source is set to Bluetooth® Audio or USB/iPod®, press left or right to navigate through audio tracks.

### **KEYLESS IGNITION**

#### **STARTING KEY FOB OPERATION:**

When the electrical system is activated with the power switch, the key fob must be within range. If the key fob is not detected, the security light will flash. The electrical system will automatically shut down.

The starter motor will not engage during this time. If a key fob is not available, your personal identification number (PIN) can be entered using the turn signal switches, or on the Ride Command display screen (if equipped), to unlock the security system. See page 152.

#### **DRIVING KEY FOB OPERATION:**

After starting the engine, the Vehicle Control Module (VCM) will verify that the key fob is within range again when shifting from neutral into gear. The security light may turn on during this check. The VCM will not search for the key fob again after the vehicle has moved. If the key fob is lost during riding, the PIN will be needed to restart the vehicle.

If the key fob is not detected when shifting into gear:

- The horn will sound and the security light will flash.
- The engine will then turn off.
- The electrical system will then automatically shut down.

### **KEY FOB STORAGE:**

The key fob should not be stored near devices that can interfere with radio waves, such as cell phones, power supplies, or magnets, during operation.







## INSTRUMENT CLUSTER

The instrument cluster includes the speedometer, indicator lamps and Multi-Function Display (MFD).









- ① Speedometer
- ② Indicator Lamps
- ③ Multi-Function Display

## INDICATOR LAMPS



| LAMP   | INDICATES             | CONDITION   |
|--|-----------------------|---|
| <br> | Cruise Control Status | <i>Amber Lamp:</i> Cruise control is enabled, but not set. When flashing, a cruise control related fault exists. <i>Green Lamp:</i> Cruise control is set to the desired speed. <i>Read the safety and operation procedures before using cruise control.</i> See page 79. |
|   | Turn Signals          | One arrow flashes when the corresponding turn signal is activated. Both arrows flash when the hazard signal is activated. <i>If there is a problem in the signal system, the lamps will flash at twice the normal rate.</i>   |
|   | Vehicle Speed         | When standard mode is selected, speed displays in miles per hour.   |
|   |                       | When metric mode is selected, speed displays in kilometers per hour.  |
|   | High Beam             | The headlight switch is set to high beam. This indicator will flash if there is a problem with the low or high beam light.  |

## INSTRUMENTS, FEATURES AND CONTROLS

| LAMP   | INDICATES  | CONDITION   |
|--|--|---|
|  | Neutral  | The transmission is in neutral and the power switch is ON.  |
|  | Low Fuel   | This lamp illuminates when approximately one gallon (3.8 liters) of fuel remains in the fuel tank. The LCD Display will switch into a Low Fuel Mileage Counter Mode to provide the rider with mileage tracking from the time the indicator was activated. |
|  | Sidestand Light (INTL Models)                        | The sidestand light will turn on anytime the sidestand is down.   |
|  | Chassis Fault  | The alert symbol illuminates if a chassis fault occurs.   |
|  | Tire Pressure Monitoring System (TPMS) (If Equipped) | The TPMS indicator illuminates if low tire pressure is detected. It will also illuminate along with the Low Battery Voltage indicator when TPMS battery power is low, requiring service.  |

| LAMP  | INDICATES           | CONDITION   |
|---|---------------------|---|
|  | Low Oil Pressure    | This lamp illuminates when oil pressure drops below a safe operating pressure while the engine is running. If this lamp illuminates while the engine is running above idle speed, turn the engine off as soon as safely possible and check the oil level. <i>If the oil level is correct and the lamp remains on after the engine is restarted, turn the engine off immediately. See your dealer.</i> |
|  | Low Battery Voltage | This lamp illuminates when battery voltage is low. Turn non-essential accessories off to conserve power. Make sure the charging system is operating properly. See page 159. This lamp also illuminates with the security light and/or power switch when the key fob battery is low, and with the TPMS lamp when the TPMS sensor battery is low.   |



| LAMP  | INDICATES         | CONDITION   |
|---|-------------------|---|
|  | ABS Not Activated | The indicator remains on until the anti-lock system activates, which occurs when vehicle speed exceeds 6 MPH (10 km/h). When the lamp is illuminated, the anti-lock brakes will not activate, but the conventional brake system will continue to operate normally.  |
|  | Check Engine      | This lamp illuminates briefly when the power switch is turned ON. This indicates proper function. <i>If this lamp illuminates while the engine is running, see an authorized dealer promptly.</i> The light will remain on if the tilt sensor shuts down the engine. If abnormal sensor or engine operation is detected the light will remain on as long as the fault condition exists. Retrieve the error codes for diagnosis. |
|  | Security          | The security indicator illuminates when the security system is activated.   |

## SPEEDOMETER

The speedometer displays forward vehicle speed in either miles per hour or kilometers per hour.

## TACHOMETER

The tachometer displays engine speed in revolutions per minute (RPM). A red line on the face of the gauge indicates the maximum safe engine speed.

Excessive engine speed can cause engine damage or failure, which could result in serious injury or death. Do not allow engine speed to exceed the red line.

### FUEL GAUGE DISPLAY

The fuel gauge displays fuel level. For the most accurate reading, sit on the motorcycle and bring it to the upright position.



The segments of the fuel gauge ① show the level of fuel in the fuel tank. When the last segment clears, a low fuel warning is activated. All segments including the fuel icon will flash. Refuel promptly.

### MULTI-FUNCTION DISPLAY MODES

With the ignition switch on, use the left-hand trigger switch to toggle through the modes of the multi-function display and to change settings in the display.

The following display modes are available:

- Odometer
- Trip Odometer
- Trip Odometer 2
- Engine Speed
- Gear Indicator
- Battery Voltage
- Engine Error Codes
- Average Fuel Economy
- Instant Fuel Economy
- Ambient Air Temperature
- Ride Modes

### ODOMETER

The odometer displays total distance traveled.

### TRIP ODOMETER

The trip odometer displays total distance traveled since being reset. To reset, toggle to the trip odometer, then press and hold the MODE button until the trip odometer resets to zero.

### ENGINE SPEED

Engine speed displays in revolutions per minute (RPM).

### GEAR INDICATOR

The vehicle's current gear position is displayed on the MFD.

## BATTERY VOLTAGE

Battery voltage displays real-time, regulated charge voltage supplied to the battery. The voltage level may fluctuate depending on electrical load and engine RPM.

## AVERAGE FUEL ECONOMY

Average Fuel Economy displays the vehicle's average fuel economy as of the last time the mode was reset. To reset, press and hold the right hand trigger while viewing the fuel economy display.

## INSTANTANEOUS FUEL ECONOMY

Instantaneous Fuel Economy displays the vehicle's current fuel economy at the moment the mode was selected.

## OUTSIDE TEMPERATURE

The temperature area displays the temperature of the air immediately surrounding the motorcycle.

## RIDE MODES (BASE MODELS ONLY)

You can choose between three ride modes, Tour, Standard, or Sport for an experience customized to your riding style. The throttle map for each ride mode was designed with a specific application in mind, resulting in one motorcycle with three distinct personalities.

### NOTICE

For the ride mode to change, the throttle must be fully disengaged. If you change the ride mode while the throttle is engaged, the ride mode icon will flash indicating that the ride mode has not yet changed. Once the throttle is disengaged, the selected mode will stop flashing and the ride mode will change.

### TOUR

Tour mode provides a smoother throttle response ideal for riding with a passenger or for long touring rides.

### STANDARD

Standard mode features a crisp throttle response and well-balanced power delivery for responsive passing power and predictable, slow-speed handling.

### SPORT

Sport mode is designed for situations when instant response is needed. Sport mode quickens the throttle response and has a more aggressive power delivery for increased acceleration.

### CHANGING RIDE MODES

1. In Menu options, press the right hand control trigger switch to select the RIDE MD option.
2. Hold the right hand trigger switch for 3 seconds to enter into the RIDE MD menu.

## INSTRUMENTS, FEATURES AND CONTROLS

---

3. Single press the right hand trigger switch to cycle through the ride mode options (TOUR, STND, SPORT).

### NOTICE

The ride mode will not change unless the throttle is in a neutral position.

4. To exit the RIDE MD menu, single press the left hand control trigger.

## DISPLAY UNITS (STANDARD/METRIC)

The display can be changed to display either standard or metric units of measurement.

|                    | STANDARD DISPLAY | METRIC DISPLAY           |
|--------------------|------------------|--------------------------|
| <b>Distance</b>    | Miles            | Kilometers               |
| <b>Temperature</b> | Fahrenheit       | Celsius                  |
| <b>Time</b>        | 12-Hour Clock    | 24-Hour Clock            |
| <b>Volume</b>      | Gallons          | Imperial Gallons, Liters |

1. Turn the ignition off.
2. Wait 10 seconds.
3. Press and *hold* the right-hand trigger switch while turning the key to the ON or PARK position.
4. When the display flashes the distance setting, tap the right-hand trigger switch to advance to the desired setting.
5. Press and *hold* the right-hand trigger switch to save the setting and advance to the next display option.
6. Repeat the procedure to change remaining display settings.

**CLOCK****NOTICE**

The clock must be reset any time the battery has been disconnected or discharged.

1. Use the right-hand trigger switch to toggle to the odometer display.
2. Press and *hold* the right-hand trigger switch until the hour segment flashes. Release the switch.
3. With the segment flashing, tap the right-hand trigger switch to advance to the desired setting.
4. Press and *hold* the right-hand trigger switch until the next segment flashes. Release the switch.
5. Repeat steps 3–4 twice to set the 10-minute and 1-minute segments. After completing the 1-minute segment, step 4 will save the new settings and exit the clock mode.

**ENGINE ERROR CODES**

The error screen displays only when the CHECK ENGINE light is on or when it goes on and off during one ignition cycle. Error codes display only during the current ignition cycle. When the ignition switch is turned OFF, the code and message is lost, but will reappear if the fault reoccurs after restarting the engine.

If the CHECK ENGINE indicator lamp illuminates, retrieve the error codes from the display.

1. If the error codes are not displayed, use the right-hand trigger switch to toggle until “Ck ENG” displays on the main line of the display.
2. Press and hold the right-hand trigger switch to enter the diagnostics code menu.
3. Record the three numbers displayed in the gear position, clock and odometer displays.
4. See an authorized dealer for code details and diagnosis.



- ① Error Code Number (0–9)
- ② Suspect Parameter Number (SPN)
- ③ Failure Mode Indicator (FMI)

## INSTRUMENTS, FEATURES AND CONTROLS

---

### DIAGNOSTIC FUNCTIONALITY

Certain conditions will cause the battery indicator to illuminate and an error message to display in the screen. If this occurs, please see your authorized dealer.

| MESSAGE | LOCATION          | INDICATES   |
|---------|-------------------|---|
| LO      | DC Voltage Screen | Voltage remains below 11.0 volts for more than 10 seconds |
| OV      | DC Voltage Screen | Voltage remains above 15.0 volts for more than 10 seconds |
| ERROR   | All               | Checksum error (gauge malfunction)                        |

### REAR CYLINDER DEACTIVATION

Designed as an aid to reduce engine and exhaust heat to the rider, Rear Cylinder Deactivation turns off the rear cylinder when the engine gets hot.

The following condition must be met for Rear Cylinder Deactivation to be enabled.

- Engine must be up to operating temperature
- Ambient Temperature must exceed 15 C
- Engine speed must remain below 1000 rpm
- Gear position must be 1, 2, or N
- Throttle must be in the closed position (0% throttle)

For models equipped with Ride Command, Rear Cylinder Deactivation can be turned off by accessing the settings menu in the drop-down from the top of the screen. Cylinder Deactivation controls are in the Vehicle Settings menu. When Rear Cylinder Deactivation is functioning, an icon will illuminate at the top of the Ride Command display screen.

For models not equipped with Ride Command, do the following to disable Rear Cylinder Deactivation:

1. Press the right-hand trigger until “CYLdeAC” displays.
2. Hold down the right-hand trigger. “CD ON” or “CD OFF” will display.
3. Toggle to turn cylinder deactivation on or off. Press and hold hand right-hand trigger to save settings.
  - CYLdeAC ON: rear cylinder can deactivate
  - CYLdeAC OFF: rear cylinder cannot deactivate

### MISFIRE DETECTION

If a misfire is detected, the check engine indicator lamp will begin to flash and fuel will be cut to the affected cylinder(s). The check engine indicator lamp will continue to flash until the ignition switch has been moved to the off position. Restarting the engine will clear the flashing indicator and restore fuel to both cylinders. If another misfire occurs, the check engine indicator lamp will resume flashing and fuel will once again be cut to the affected cylinder(s). After the 3<sup>rd</sup> misfire, P0314 misfire fault is determined & set, the check engine light will remain on and fuel will be cut to the affected cylinder(s). If this occurs, your INDIAN MOTORCYCLE dealer can assist.

## HEADLIGHTS

The headlights automatically come on when the engine is started.

### WARNING

Motorcycle riders must remain as visible as possible at all times. To aid in this, the headlight must be on at all times. Do not modify the ignition/headlight wiring to circumvent the automatic headlight feature.

The headlights operate only when the engine is running. You can use the high/low headlight beam switch to override this function and allow the headlights to operate when the engine is not running. Turn the power switch on, then toggle the high/low headlight beam switch to turn the headlights on.

## THROTTLE CONTROL GRIP

The throttle control grip is located on the right handlebar. Use the throttle control grip to control engine speed.

While seated in the proper riding position:

- Roll the grip rearward ① to open the throttle (increase engine speed and power).
- Roll the grip forward ② to close the throttle (decrease engine speed and power), and cancel cruise control.

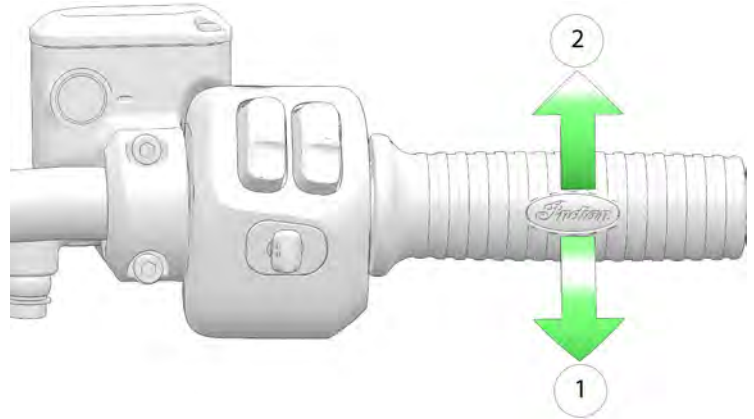

The control grip is spring loaded. When you release the grip, the throttle returns to the idle position.

### CLUTCH LEVER

The clutch lever ① is located on the left handlebar. Disengage the clutch before shifting gears. For smooth clutch operation, pull the lever quickly and release it in a brisk but controlled manner.

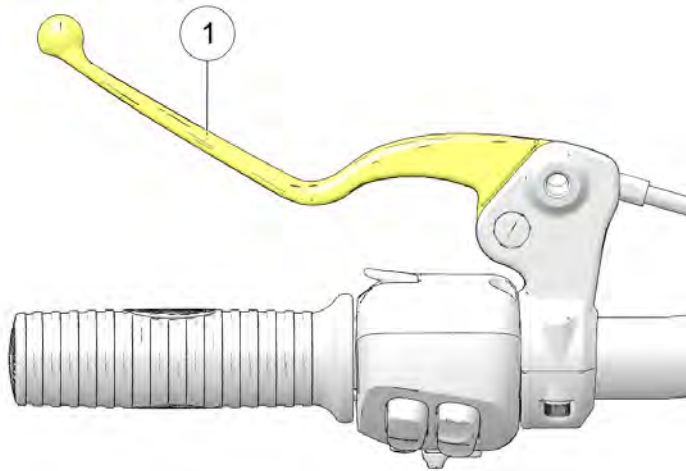

- To disengage the clutch, pull the lever toward the handlebar.
- To engage the clutch, release the lever in a brisk but controlled manner.

### GEAR SHIFT LEVER

The gear shift lever is located on the left side of the motorcycle. Operate the lever with your foot.

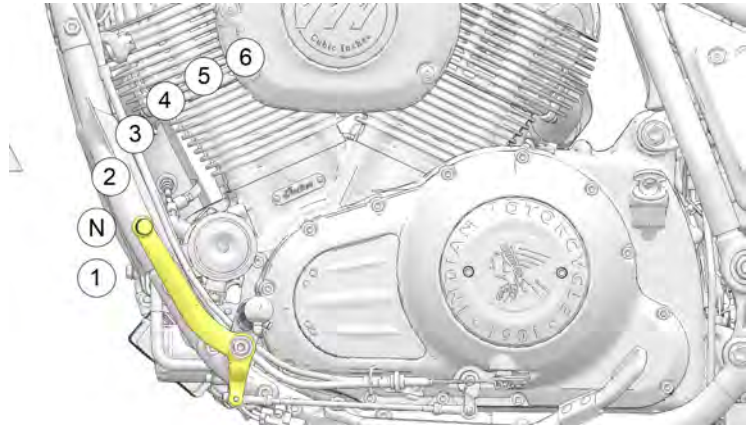

- Press downward on the toe lever to shift to a lower gear.
- Lift upward on the toe lever to shift to a higher gear.
- Release the lever after each gear shift.
- See page 75, for gear shifting procedures.



## TIRE PRESSURE MONITORING SYSTEM (TPMS) (IF EQUIPPED)

### NOTICE

On models equipped with a TPMS, the sensors are located 180° from the valve stem. Use caution when servicing tires. To avoid damaging a sensor, break the bead at the valve stem, then at 90° and 270° from the valve stem as required.

With a TPMS, the pressure of each tire can be viewed in the MFD and in the display for Infotainment motorcycles on rider screens. If dashes display instead of a pressure value while traveling above 15 MPH (24 km/h), the system may not be functioning properly. See your dealer for service.

The TPMS warning indicator will illuminate if low tire pressure is detected. Always correct low tire pressure promptly. Always inspect tire pressure and condition before each ride. See page 64.

The TPMS display may indicate an increase in tire pressure while riding, a normal occurrence as tires warm up. Riding into colder conditions may result in a drop in tire pressure as tires cool down. Regardless of conditions, low tire pressures should always be corrected promptly.

## SADDLEBAGS (IF EQUIPPED)

Do not exceed the weight limit of each saddlebag. Always distribute weight evenly in each of the saddlebags. Refer to the saddlebag/cargo warning label on or near the saddlebag for cargo capacity.

Soft bag capacity is 10 lbs. (4.5 kg) of cargo per side.

### SOFT BAG REMOVAL

1. Unbuckle the saddlebag lid clasps and open the lid.
2. Remove the saddlebag fastener bolts.
3. Remove the saddlebag lower support bolts ① from the passenger foot peg mount.

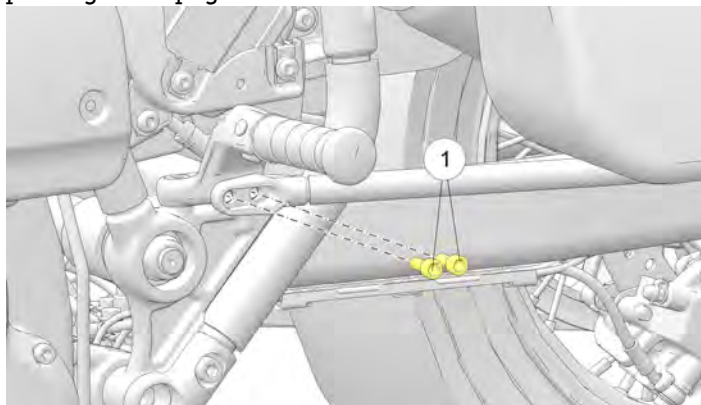

## INSTRUMENTS, FEATURES AND CONTROLS

4. Lift the saddlebag straight up, and then straight out to remove.

### WARNING

Improper saddlebag installation can result in loss of control, accident and driving hazards for other motorists (if saddlebag falls from the motorcycle). Always make sure saddlebag are mounted properly.

5. To reinstall, place the soft bag in position.
6. Install the saddlebag fastener bolts and torque to specification.

### TORQUE

18 ft-lbs (24 Nm)

## SIDESTAND

### WARNING

An improperly retracted sidestand could contact the ground and cause a loss of control resulting in serious injury or death. Always retract the sidestand fully before operating the motorcycle.

To park the motorcycle, swing the end of the sidestand downward and away from the motorcycle until it is fully extended. Always turn the handlebars to the left for maximum stability. Lean the motorcycle to the left until the sidestand firmly supports the motorcycle.

### CAUTION

If the motorcycle weight is not resting on the sidestand, it will not lock. In this situation, any movement of the motorcycle could cause the sidestand to retract slightly. If the sidestand is not in the full forward position when the motorcycle weight is rested on it, the motorcycle could fall over, possibly causing injury and damage to the motorcycle.

To retract the sidestand, straddle the motorcycle and bring it to the fully upright position. Swing the end of the sidestand upward and toward the motorcycle until it is fully retracted.

The sidestand may be equipped with a safety switch that prevents operation of the motorcycle if the sidestand is deployed.

## WINDSHIELD (IF EQUIPPED)

### WINDSHIELD REMOVAL

1. Remove the two screws ① from the upper windshield latches, and rotate the two latches upward.



2. From the front of the motorcycle, pull firmly on the upper windshield to remove the windshield from the upper mounts, then pull the windshield upward and away from motorcycle.
3. Reverse this procedure to reinstall the windshield. Rotate the latches fully downward to secure the windshield and reinstall the screws.

### WINDSHIELD CARE (IF EQUIPPED)

Clean the windshield with a soft cloth and plenty of warm water. Dry with a soft clean cloth. Remove minor scratches with a high-quality polishing compound designed for use on polycarbonate surfaces.

#### NOTICE

Brake fluid and alcohol will permanently damage the windshield. Do not use glass cleaners, water or soil repellents, and petroleum or alcohol based cleaners on the windshield, as these products can damage the windshield.

## MIRRORS

Your vehicle is equipped with convex mirrors. Objects seen in a mirror may be closer than they appear. Always adjust mirrors before riding.

To adjust the mirrors, sit on the motorcycle in the anticipated riding position. Adjust the mirrors so that you can see a small portion of your shoulders in each mirror.

## BRAKES

The front brake lever activates the front brake caliper. The rear brake pedal activates the rear brake caliper. For maximum brake effectiveness, apply the front brake lever and the rear brake pedal together.

### ANTI-LOCK BRAKE SYSTEM (ABS) (IF EQUIPPED)

The anti-lock brake system automatically adjusts brake pressure as needed to provide optimum braking control, reducing the chance of wheel lock-up during hard braking events or when braking on rough, uneven, slippery or loose surfaces. See page 15.

1. The anti-lock brake system cannot be turned off.
2. The ABS indicator always illuminates when vehicle power is turned on. It remains illuminated until the anti-lock system activates, which occurs when vehicle speed exceeds 6 MPH (10 km/h).
3. When the lamp is illuminated, the anti-lock brakes will not activate, but the conventional brake system will continue to operate normally.
4. When the anti-lock brakes engage during a braking event, the rider will feel pulsing at the brake levers. *Continue to apply steady pressure to the brakes for the best stopping performance.*
5. If the ABS light does not come on when the key is turned to the ON or PARK position, your authorized INDIAN MOTORCYCLE dealer can assist.

- If the lamp continues to illuminate after vehicle speed exceeds 6 MPH (10 km/h), the ABS system is not functioning. See your INDIAN MOTORCYCLE dealer or other dealer promptly for service.
- Operating with non-recommended tires or improper tire pressure may reduce the effectiveness of the anti-lock brake system. Always use the recommended size and type of tires specified for your vehicle. Always maintain the recommended tire pressure.
- The anti-lock brake system will not prevent wheel lockup, loss of traction or loss of control *under all conditions*. Always adhere to all safe motorcycle-riding practices as recommended.
- It is not unusual to leave tire marks on the road surface during a hard braking event.
- The anti-lock brake system does not compensate for or reduce the risks associated with:
  - excessive speed
  - reduced traction on rough, uneven or loose surfaces
  - poor judgment
  - improper operation

## FRONT BRAKE LEVER

The front brake lever ① is located on the right handlebar. This lever controls only the front brakes. The front brakes should be applied simultaneously with the rear brakes. To apply the front brake, pull the lever toward the handlebar. See page 77 for braking procedures.

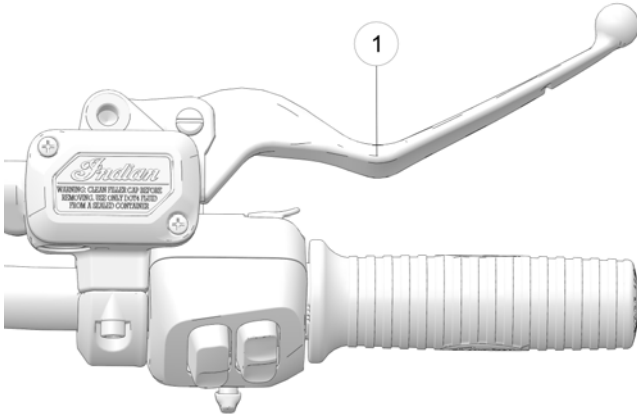

## REAR BRAKE PEDAL

The rear brake pedal ① is located on the right side of the motorcycle. Press downward on the rear brake pedal to apply the rear brake.

### WARNING

Resting your foot on the brake pedal will cause excessive and premature wear of brake pads and reduced braking efficiency, which could result in serious injury or death.

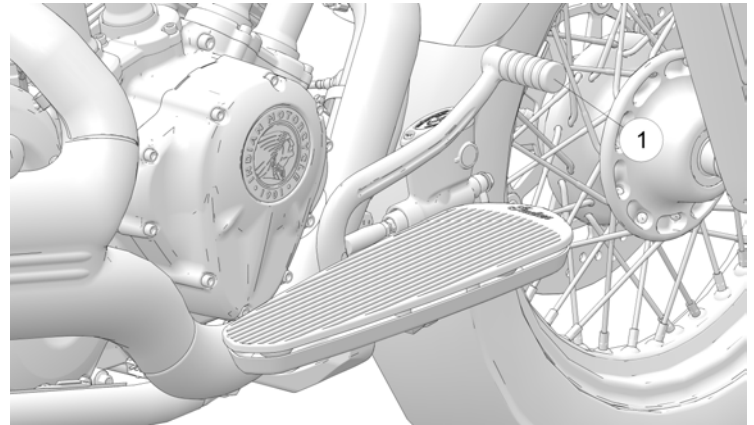

See page 77 for braking procedures.

### FUEL CAP

The fuel filler cap ① is located on the right side of the fuel tank.

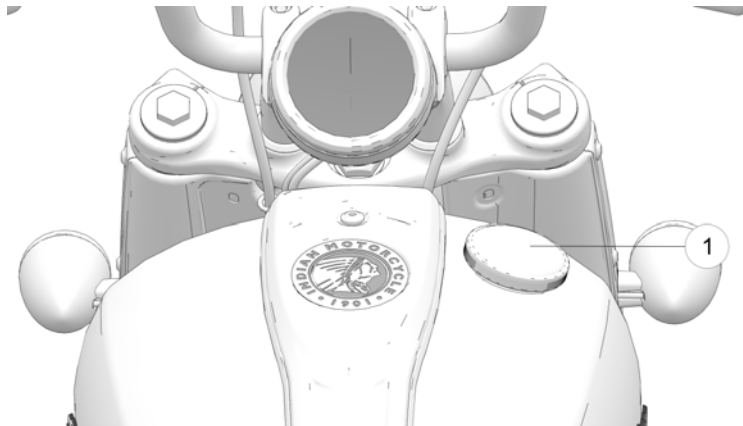

Turn the fuel cap counter-clockwise to remove it. If the fuel cap is equipped with a tether, carefully rest fuel cap on the tank so that the rubber bumper is contacting the tank. See page 72 for fueling instructions. To tighten the cap, turn it clockwise until the seal compresses onto the tank, then continue to tighten until the cap ratchets several times.

## RIDE COMMAND (IF EQUIPPED) OVERVIEW



For the latest information about your INDIAN MOTORCYCLE Ride Command display, including software updates, please visit <https://ridecommand.indianmotorcycle.com>

### NOTICE

Using the display for an extended period of time while the vehicle's engine is off can drain the battery.

### WARNING

Do not enter information while operating your vehicle. Failure to pay attention to operating your vehicle could result in loss of control, injury, or death. You assume all risks associated with using this device. Read your User Guide.

### WARNING

Driving while distracted can result in loss of vehicle control, crash, and injury. We strongly recommend that you use extreme caution when using any device that may take your focus off the road. Your primary responsibility is the safe operation of your vehicle. We recommend against the use of any hand-held device while driving and encourage the use of voice-operated systems when possible. Make sure you are aware of all applicable local laws that may affect the use of electronic devices while driving.

Before riding with your new display, do the following:

- Read this entire manual.
- Familiarize yourself with the features and operations of the display while the vehicle is stationary.
- Download the INDIAN MOTORCYCLE Ride Command app from the APPLE APP STORE® or Google Play® store and create your personalized account.
- Check <http://www.polaris.com/en-us/rider-support/owners-manual> for the latest updates to the owner's manual.

## RIDE COMMAND (IF EQUIPPED)

---

### BEFORE YOU RIDE

Before riding with your new display, do the following:

- Read this entire manual.
- Familiarize yourself with the features and operations of the Display while the vehicle is stationary.
- Download the Polaris RIDE COMMAND App from the APPLE APP STORE®/Google Play® store and create your personalized account.
- Check your display to ensure you have the appropriate maps visible for your area. To change or update maps, see the *Ride Command Quickstart Guide*.
- Check <https://www.polaris.com/en-us/owners-manuals/> for the latest updates to the owner's manual.

#### NOTICE

Using the display for an extended period of time while the vehicle's engine is off can drain the battery.

### DEVICE OPERATING REQUIREMENTS

Phone functionality is dependent on the capabilities of your cell phone.

#### NOTICE

Some cell phones or operating systems will not work as shown in this manual.

### CARE AND MAINTENANCE

To clean the display shell, use a soft cloth with mild soap and water. Do not use harsh or abrasive cleaners. For best results, use a micro-fiber towel to clean the screen. Window cleaner or alcohol may also be used.

#### NOTE

Immediately clean off any gasoline that splashes on the display.







## GETTING STARTED OVERVIEW



- ① Touchscreen Buttons
- ② Indicator Lamps
- ③ Turn Signal Indicators
- ④ Current Gear
- ⑤ Speedometer
- ⑥ Icon Bar

## RIDE COMMAND BUTTONS

| BUTTON   | FUNCTION   |
|--|--|
|   | Press the Screen Cycle button to toggle through available display screens. |
|  | Press the Controls button to access vehicle and display settings.          |
|  | Press the App Tray button to access the Settings and Phone screens.        |
|  | Press the Back button to back out of menu screens.                         |

## RIDE COMMAND (IF EQUIPPED)

### ICON BAR

The Icon Bar displays information, such as cell signal strength, current ride mode, and more.



- ① Headset Connection
- ② Cruise Control
- ③ Cell Signal Strength
- ④ Clock
- ⑤ Ride Mode

### DISPLAY SCREENS

Press the Screen Cycle button ①, or the trigger switch on the left hand control, to cycle through the available display screens.



| DISPLAY SCREENS     | FUNCTION   |
|---------------------|--|
| Gauge Screen        | Displays important information, such as speedometer, tachometer, gear, vehicle direction, ambient temperature, odometer, and fuel level. |
| Bike Information    | Displays bike information, such as ambient temperature, battery voltage, tire pressure, fuel economy, and fuel range.                    |
| Ride Information    | Displays ride information, such as ride time, distance, elevation, and trip odometer.  |
| Maps and Navigation | Provides access to maps and turn-by-turn navigation.   |
| Audio               | Select audio source and control audio playback.  |
| Controls            | Select ride mode and change display brightness.  |

## DISPLAY SCREEN

The Display Screen displays important ride data and vehicle information, such as vehicle speed, current gear, fuel level, and more.



- ① Speedometer
- ② Tachometer
- ③ Current Gear
- ④ Vehicle Direction
- ⑤ Ambient Temperature
- ⑥ Odometer
- ⑦ Fuel Level

## RIDE COMMAND (IF EQUIPPED)

### DISPLAY SCREEN THEMES

There are two Display Screen themes to choose from, **Standard** and **Analog Sport**. The Display Screen themes can be changed in the settings menu.

#### Standard

The Standard theme resembles a classic analog dial-face, with a traditional speedometer design.



#### Analog Sport

For a slightly cleaner look, the Analog Sport theme displays the speedometer as a numeric value rather than a meter.



### BIKE INFORMATION

The Bike Information screen displays important information about your vehicle, such as front and rear tire pressure (if equipped/installed), fuel economy, and more.



① Ambient Temperature

② Rear Tire Pressure

③ Fuel Economy

④ Battery Voltage

⑤ Front Tire Pressure

⑥ Fuel Range

## RIDE INFORMATION

The Ride Information screen displays important ride information, such as your current ride time, total distance traveled, and more.



- ① Ride Time
- ② Time Moving/Stopped
- ③ Reset Trip Odometer
- ④ More Information
- ⑤ Distance Traveled
- ⑥ Current Elevation
- ⑦ Select Trip Meter

## MAPS AND NAVIGATION

The Maps and Navigation screen allows access to Ride Command's many navigation features. From the maps and navigations screen you can find directions, look up addresses, search for gas stations, and pinpoint other points of interest. Once selected, the display will provide turn-by-turn directions to your destination.



## RIDE COMMAND (IF EQUIPPED)

### MUSIC

The Music screen allows you to access music stored on your smartphone or other music device. You can pair your device using Bluetooth®, or by connecting it to the display's USB port.



- ① Select Source
- ② Track Information
- ③ Track Length
- ④ Repeat Track

- ⑤ Menu
- ⑥ Track Control
- ⑦ Shuffle

### CONTROLS

From the Controls screen you can select your ride mode and adjust the display brightness.



- ① Ride Mode
- ② Display Brightness
- ③ Close

## APP TRAY

Press the App Tray hard button ① to cycle through the available app screens.



## SETTINGS

From the Settings Menu you can view important details about your vehicle and personalize your touchscreen display. The settings menu is comprised of four categories: Information, General, Time, and Vehicle. See page 56 for more information.

## PHONE

If the Ride Command display is connected to a phone using Bluetooth®, the Phone screen will be available from the App Tray. From the phone screen you can make and answer calls, and view text messages.



## RIDE COMMAND (IF EQUIPPED)

---

### RIDE COMMAND HAND CONTROLS

#### MEDIA SWITCH

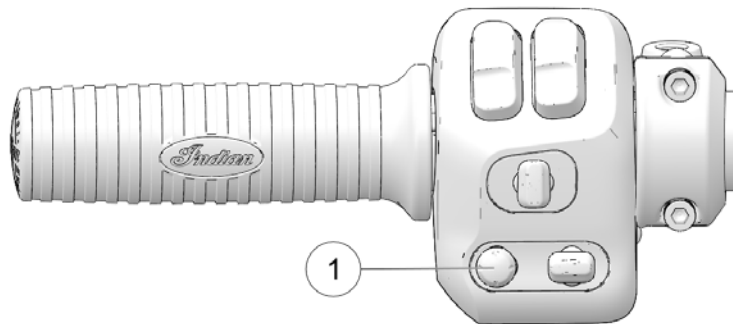

Use the 5-way media switch ① to do the following:

- Press center to mute
- Press up/down to increase/decrease volume.
- Press left/right to move to previous/next track.

#### SELECT SWITCH

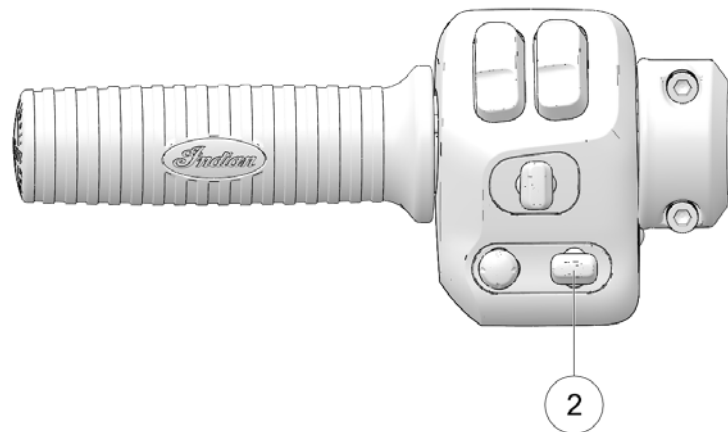

Use the 3-way select switch ② to do the following:

- Press up and down to navigate display screen.
- Press center to select.



## TRIGGER SWITCHES

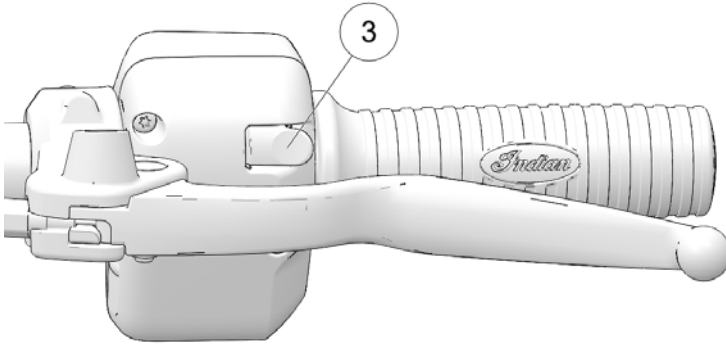

There are trigger switches located on the reverse side of both the right and left ③ switch cubes.

Use the trigger switches to do the following:

- Press the right trigger switch to confirm selection.
- Press the left trigger switch to back out of menu screens.

## RIDE COMMAND RIDE MODES

You can choose between three ride modes, Tour, Standard, or Sport for an experience customized to your riding style.

The throttle map for each ride mode was designed with a specific application in mind, resulting in one motorcycle with three distinct personalities.



### NOTICE

For the ride mode to change the throttle must be fully disengaged. If you change the ride mode while the throttle is engaged, a spinning icon will appear indicating that the ride mode has not yet changed. Once the throttle is disengaged the icon will disappear and the ride mode will change.

## RIDE COMMAND (IF EQUIPPED)

### TOUR

Tour mode provides a smoother throttle response ideal for riding with a passenger or for long touring rides.

### STANDARD

Standard mode features a crisp throttle response and well-balanced power delivery for responsive passing power and predictable, slow-speed handling.

### SPORT

Sport mode is designed for situations when instant response is needed. Sport mode quickens the throttle response and has a more aggressive power delivery for increased acceleration.

## SETTINGS

From the Settings Menu you can view important details about your vehicle and personalize your touchscreen display.

The settings menu is comprised of four categories: Information, General, Time, and Vehicle.



## INFORMATION

From the Information settings menu you can view the following:

- Vehicle Identification Number (VIN)
- Mileage
- Installed Software Version
- Oil Change Interval

## GENERAL SETTINGS

From the General settings menu you can do the following:

- Themes (Day/Night/Auto)
- Manage Bluetooth® Devices
- Change the Language
- Set the Speed Units of Measure (MPH or KPH)
- Set the Temperature Units (F or C)
- Update Software

## TIME

From the Time Settings you can do the following:

- Set the Time Format (12 hour or 24 hour)
- Enable GPS Time (automatically sets the time to the time zone you are currently in)
- Set Time (if GPS Time is not enabled)

### NOTICE

The clock is sourced from the GPS chip and periodically requires GPS lock to function correctly.

### NOTICE

Clock reading will be non-existent or inaccurate after disconnecting battery and will require a new GPS sync to function properly.

## VEHICLE

From the Vehicle Settings you can do the following:

- Oil Life/ Service Reset
- Access Vehicle Diagnostics

## BLUETOOTH® PAIRING

The INDIAN MOTORCYCLE Ride Command touchscreen display can be connected to a smart-phone and a headset simultaneously.

### NOTICE

Always pair the smart-phone first, followed by accessories.

To pair a device, do the following:

1. From the Bluetooth® Devices settings screen, the Phone screen, or the Music screen, tap on the Add Device button to bring up the pairing prompt.
2. Put your Bluetooth® device into pairing mode.
3. Select the name of the device you want to pair from the touchscreen display to finish the pairing process.
4. Confirm pairing (if applicable). Depending on the device you are pairing to the display you may be prompted to confirm pairing.

## RIDE COMMAND (IF EQUIPPED)

### CONNECTED SERVICES

Certain INDIAN MOTORCYCLE Ride Command equipped models include connected services, provided for a limited time starting on the date of purchase. The features include real time traffic, weather, and enhanced destination search capabilities. To check your connected service status and to renew, go to:<http://ridecommand.indianmotorcycle.com>.

### UPDATE SOFTWARE

For the latest software for INDIAN MOTORCYCLE Ride Command, go to:  
<https://ridecommand.indianmotorcycle.com>.

The display software can be updated by connecting a USB stick containing the latest software version to the USB port located on the bottom left of the display. The Update Software menu in Settings will list any available updates on the USB stick. Choose the correct version and wait for the update to complete before removing the USB stick. The touchscreen display will automatically restart when software is updated.

#### NOTICE

A USB 2.0 or USB 3.0 flash drive formatted to either FAT-32 or ex-FAT is required to successfully perform an update. The display will not recognize flash drives that do not meet these requirements.

#### IMPORTANT

Do not remove power from the display during the update process.

### OVER THE AIR UPDATES

#### NOTICE

Over the air updates are only available on models equipped with a cell modem.

If your model is equipped with a cell modem, the motorcycle will automatically download software updates from the cloud when the motorcycle is powered on and a cell modem connection is available. All downloads occur in the background and can be resumed if the connection is interrupted or if the motorcycle is turned off.

### HOW TO INSTALL SOFTWARE

Once new software has been downloaded to your display, you will be prompted with a notification.

To install new software, do the following:

1. Navigate to the General Settings tab in the Settings menu.
2. Press the “Install” button.

### NOTICE

The following conditions must be met for the installation to initiate: the battery voltage must be greater than 12.5 V, the wheel speed must be at 0 mph, and the RPMs must equal 0.

### NOTICE

The display will restart after the installation has successfully completed.

### NOTICE

Critical updates will be installed automatically. A notification will display once the update is complete.

3. After the update had been completed, release notes will be provided on the software update screen.

## UPDATE MAPS

For the latest maps for Ride Command, go to <https://ridecommand.indianmotorcycle.com>.

### NOTICE

The display will automatically restart after a software and map update.

### NOTICE

For map updates, a 32GB or greater USB drive formatted to exFAT is required.

## RIDE COMMAND (IF EQUIPPED)

---

### USB PORT

The USB Port ① makes it easy to power devices, such as phones, audio sources, or GPS units, in addition to allowing you to stream music through the LCD display to your Bluetooth® headset. On models equipped with a INDIAN MOTORCYCLE Ride Command display, the USB port is also used to update the display software. For the latest software, go to <https://ridecommand.indianmotorcycle.com>.

#### IMPORTANT

Due to harsh riding environments, INDIAN MOTORCYCLE recommends using a USB device with retention features.

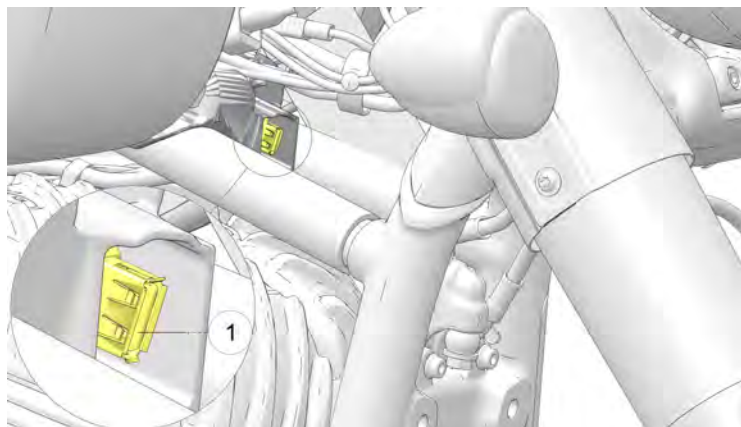

## PRE-RIDE INSPECTIONS BEFORE YOU RIDE

To keep your motorcycle in safe operating condition, always perform the recommended pre-ride inspections before each ride. This is especially important before making a long trip and when removing the motorcycle from storage.

### WARNING

Failure to perform the recommended pre-ride inspections could result in component failure while riding, which could result in serious injury or death. Always perform the pre-ride inspections before each ride. When inspection reveals the need for adjustment, replacement or repair, perform the service promptly, or your authorized INDIAN MOTORCYCLE can assist.

### WARNING

Read the entire Instruments, Features and Controls section of this manual before riding your motorcycle. A complete understanding of the features and capabilities of your motorcycle is essential to its safe operation. Anything less may result in serious injury or death.

You must be familiar with all instruments and controls to perform the pre-ride inspections.

### TIP

During the pre-ride inspections you may use products that are potentially hazardous, such as oil or brake fluid. When using any of these products, always follow the instructions and warnings on the product packaging.

When inspections reveal the need for adjustment, replacement or repair:

- refer to the maintenance section of this manual ( page 83)
- refer to the INDIAN MOTORCYCLE Service Manual
- or see your authorized INDIAN MOTORCYCLE dealer or other dealer

## ELECTRICAL INSPECTIONS

Turn the power switch on and move the stop/run switch to RUN before performing the following electrical inspections. Turn the power switch off after completing these inspections. If inspection of any electrical item reveals component failure, repair or replace the component before operating the motorcycle.

## PRE-RIDE INSPECTIONS

| ITEM                      | INSPECTION PROCEDURE  |
|---------------------------|---|
| Headlamp                  | Move the headlight switch from low beam to high beam to turn the lights on and verify operation of both beams. Start the engine. Switch to high beam. Verify that the high beam indicator comes on and that lamp brightness increases. Press and hold the low beam switch to verify "Flash to Pass" functionality.                                      |
| Taillights/<br>Brakelight | Verify that the taillights and license plate light illuminate. Verify that the taillight lamps increase in brightness when the front brake lever is applied and also when the rear brake pedal is applied.  |
| Turn Signals              | Move the turn signal switch to the left. Verify that front and rear left turn signals flash, as well as the corresponding light on the indicator panel. Move the switch to the center position and push it inward to cancel the signal. Verify that the signals and the indicator light stop flashing. Repeat the procedure for the right turn signals. |
| Emergency Flashers        | Press and hold the turn signal switch in for 1 second to activate flashers. Verify that all four turn signals flash, as well as the lamps on the indicator panel. Turn the flashers off. Verify that all signals and indicator lamps stop flashing.   |
| Horn                      | Press the horn switch. Verify that the horn sounds loudly.  |
| Neutral Indicator         | Place the transmission in neutral. Verify that the neutral indicator lamp illuminates and that the letter "N" displays in the gear position display.  |

| ITEM                     | INSPECTION PROCEDURE   |
|--------------------------|--|
| Low Oil Pressure Display | Start the engine. Verify that "LO OIL" is not displayed in the MFD.                            |
| Engine Stop/Run Switch   | Start the engine. Move the stop/run switch to the STOP position. Verify that the engine stops. |

## GENERAL INSPECTIONS

| ITEM               | INSPECTION PROCEDURE   |
|--------------------|--|
| Engine Oil         | Check the oil level. See page 63   |
| Fuel               | Check the fuel level. See page 72.   |
| Fluid Leaks        | Check the vehicle and the ground/floor for any fuel, oil or hydraulic fluid leaks. |
| Tires              | Inspect condition, pressure and tread depth. See page 130.                         |
| Brake Operation    | Inspect pedal and lever movement.  |
| Brake Fluid Levels | Check front and rear brake fluid levels.   |
| Brake Components   | Inspect hoses and connections.   |
| Throttle           | Inspect hand grip and throttle movement.   |
| Clutch             | Check lever operation and freeplay.  |
| Front Suspension   | Check for leaks, debris and damage.  |



| ITEM             | INSPECTION PROCEDURE  |
|------------------|---|
| Steering         | Check for smooth operation by turning handlebars full left and full right.                                |
| Rear Suspension  | Inspect for leaks. Check shock movement and air pressure.   |
| Ride Height      | Make sure shock pressure is adjusted properly for load.   |
| Rear Drive Belt  | Check for wear or damage. Check drive belt tension. See page 111.   |
| Sidestand        | Verify smooth operation, inspect pivot bolt and spring.   |
| Fasteners        | Inspect for loose, damaged or missing fasteners.  |
| Mirrors          | Adjust for proper rear view.  |
| Trunk/Saddlebags | If equipped, make sure the trunk and saddlebags are properly installed and that lids are securely closed. |

### ENGINE OIL LEVEL

With the semi-dry sump lubrication system, the engine oil level on the dipstick will fluctuate, depending on the motorcycle's position and engine temperature when checked. To ensure a proper reading of the engine oil level, follow all inspection procedures closely.

#### WARNING

Operating with insufficient, deteriorated or contaminated engine oil will cause accelerated wear and may result in engine or transmission seizure, which could result in loss of control and serious injury or death. Check the oil level frequently.

Always check the oil after running a cold engine at idle for 30 seconds. The oil fill/dipstick is located on the left side of the motorcycle. Always use the recommended oil. See page 175.

1. Position the motorcycle on level ground in the fully upright and centered position.
2. Start the engine (from cold) and allow it to idle for 30 seconds. Stop the engine.
3. Remove the dipstick ① and wipe it clean.

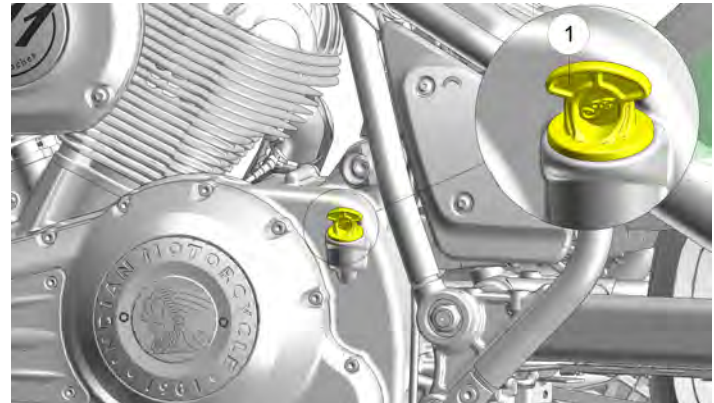

4. Thread the dipstick until fully seated.

## PRE-RIDE INSPECTIONS

- Remove the dipstick and view the oil level.

### NOTICE

Do not overfill. Overfilling can result in loss of engine performance and an oil-saturated air filter. Use a suction device to remove excess oil if overfilled.

- Add the recommended oil as needed to bring the level between the ADD and FULL marks. Do not add oil if between the ADD and FULL marks.

### TIP

The approximate volume between the FULL ② and ADD ③ marks on the dipstick is 32 oz. (.94 L).

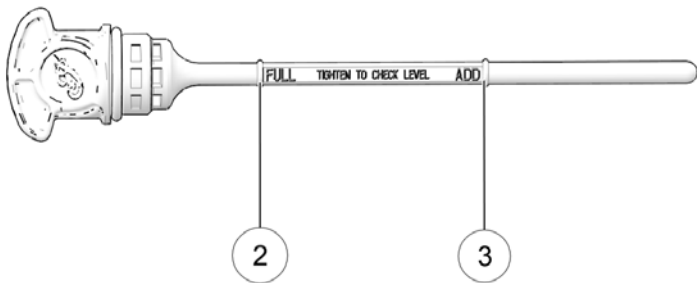

- Reinstall the dipstick securely.

## TIRES

### WARNING

Operating the motorcycle with incorrect tires, incorrect tire pressure or excessively worn tires could cause loss of control or accident. Underinflation can cause a tire to overheat and result in a tire failure. Only use tires approved by INDIAN MOTORCYCLE for the model of the motorcycle. See your dealer. Use of unapproved or an improperly mixed front and rear tire can result in decreased handling performance and stability, potentially leading to reduced control of the motorcycle. Always maintain proper tire pressure as recommended in the rider's manual and on safety labels.

## TIRE PRESSURE

Improper tire pressure can result in irregular tire wear, tire failure, reduced fuel economy and a poor riding experience. It can also affect handling and stopping ability.

Slow tire pressure loss over time is normal for a functional tire. Although a tire pressure monitoring system (TPMS) will alert the user to a low pressure condition (if equipped), always inspect tire pressure and condition before each ride.

Check tire pressure before riding, when the tires are cold. This will provide the most accurate reading, as riding warms the tires and increases tire air pressure. Tires remain warm for at least 3 hours after a ride. Do not adjust tire pressure immediately after riding. As tires cool, the pressure will drop and result in underinflation. Always check and adjust tire pressure when tires are cold.

Using supplied air pressure gauge, adjust tire pressure to the recommended pressure. See page .

### TIRE CONDITION

Inspect the tire sidewalls, road contact surface and tread base. If inspection reveals cuts, punctures, cracks or other wear or damage, replace the tire before riding. Only use tires approved by INDIAN MOTORCYCLE for the model of the motorcycle. See your dealer. Use of unapproved or an improperly mixed front and rear tire can result in decreased handling performance and stability, potentially leading to reduced control of the motorcycle.

### TIRE TREAD DEPTH

Measure the tread depth near the center of the tread on both tires. See page 128. Replace any tire with a tread depth of less than 1/16 inch (1.6 mm).

## FRONT BRAKE FLUID LEVEL

1. Bring the motorcycle to the fully upright position. Position the handlebars so that the fluid reservoir is level.
2. View the fluid level through the sight glass ①. The fluid should be clear. Replace cloudy or contaminated fluid.

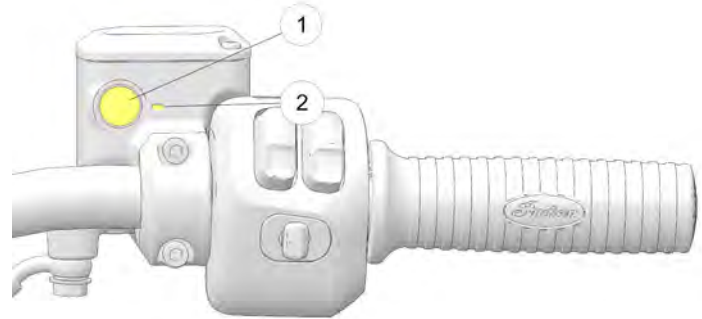

3. The fluid level should be above the minimum indicator mark ② in the sight glass.
4. If the fluid level is low, inspect brake pads as outlined on page 126. If pads are not worn beyond the service limit, inspect the brake system for leaks. Check for signs of brake fluid leaks around hoses, fittings, reservoir, and brake calipers.
5. Add brake fluid if necessary. See page 125.

## PRE-RIDE INSPECTIONS

---

### FRONT BRAKE LEVER

1. Pull the front brake lever toward the handlebar and hold it. The lever should move freely and smoothly. The lever should feel firm and continue to feel firm until released.
2. Release the lever. It should return to its rest position quickly when released.
3. If the front brake lever fails to perform as stated, service the brake lever before riding.

### REAR BRAKE PEDAL

1. Press downward on the rear brake pedal. It should move freely and smoothly. The pedal should feel firm and continue to feel firm until released.
2. Release the pedal. It should return to its rest position quickly when released.
3. If the rear brake pedal fails to perform as stated or travels too far before beginning to engage the brake, service the brakes before riding.

### REAR BRAKE FLUID LEVEL

The rear brake fluid reservoir is located near the rear brake pedal. View the reservoir level from the right side of the vehicle.

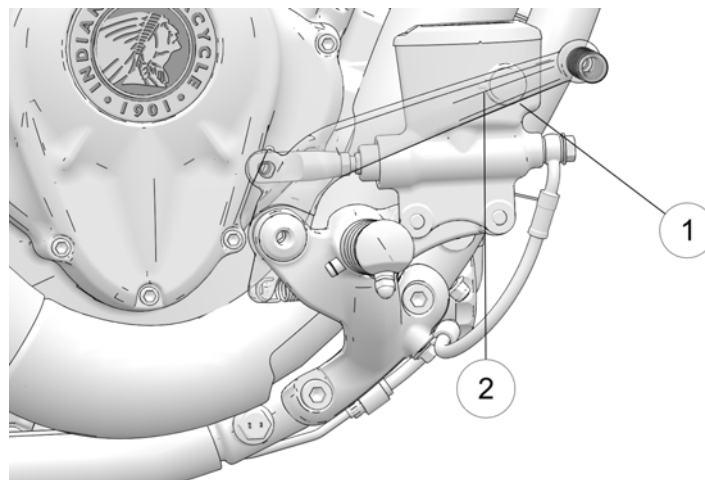

1. Position the motorcycle on level ground in the fully upright position.
2. View the brake fluid through the reservoir ①.
3. The fluid should be clear. Replace cloudy or contaminated fluid.
4. The fluid level should be above the minimum indicator mark ② on the reservoir body. Add brake fluid as needed.

## BRAKE LINES

Inspect all brake hoses and connections for dampness or stains from leaking or dried fluid. Tighten any leaking connections to the proper torque values and replace components as necessary. See the *INDIAN MOTORCYCLE Service Manual* or an authorized INDIAN MOTORCYCLE dealer or other qualified dealer.

 **WARNING**

Brake fluid leaks or low brake fluid levels could cause brake system failure, which could result in serious injury or death. Do not operate the vehicle with low brake fluid levels or when leaks are evident (dampness or stains from dried fluid). See your authorized INDIAN MOTORCYCLE dealer or other qualified dealer.

## THROTTLE

Rotate the throttle control grip. It should rotate smoothly from the rest position to the completely open position. It should return to the rest position quickly when released.

## SIDE-STAND

1. On level ground, straddle the motorcycle and bring it to the fully upright position.
2. Move the side-stand up to the stored position and down to the fully extended position several times. It should move smoothly and quietly. Make sure the return spring holds the side-stand tightly in place when the side-stand is in the stored position. Adjust or replace a loose spring.
3. Inspect the side-stand pivot bolt for looseness or wear. Tighten or replace a loose or worn bolt.

## INTL MODELS

Periodically test the side-stand safety switch for proper operation. With the transmission in gear and brakes applied, attempt to start the engine while the side-stand is down. The engine should NEVER start in any gear except neutral if the side-stand is down. If the engine starts during this test, see your dealer for service.

## PRE-RIDE INSPECTIONS

### MECHANICAL CLUTCH

1. Squeeze the clutch lever ① toward the handlebar and release it. It should move freely and smoothly, and it should return to the rest position quickly when released. If the lever fails to perform as stated, service the clutch lever before riding.

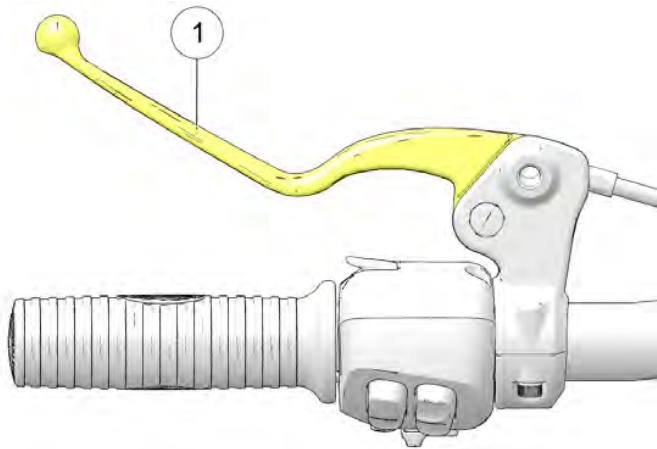

2. Freeplay (gap) is the amount of lever movement from the rest position to the point of cable resistance. Clutch lever freeplay should be 0.5-1.5 mm. Measure the gap between the clutch lever and the lever housing. Adjust clutch lever freeplay if necessary.

#### NOTICE

The starter interlock switch is dependent on the clutch lever freeplay being set correctly to ensure activation of the clutch safety switch.

### FASTENERS

1. Inspect the entire motorcycle chassis and engine for loose, damaged or missing fasteners.
2. Tighten loose fasteners to the proper torque. See the *INDIAN MOTORCYCLE Service Manual* or an authorized *INDIAN MOTORCYCLE* dealer or other qualified dealer.

#### NOTICE

Always replace stripped, damaged or broken fasteners before riding. Use genuine *INDIAN MOTORCYCLE* fasteners of equal size and strength.

### FRONT SUSPENSION

Inspect the front forks for oil leaks or damage, and verify smooth suspension operation. See page 118.

## STEERING

1. On level ground, straddle the motorcycle and bring it to the fully upright position. Turn the handlebars from stop to stop. The action should be smooth, but not loose.
2. Make sure wires, hoses and control cables do not interfere with smooth steering.

## REAR SUSPENSION

Check rear shock absorber movement to ensure the correct amount of suspension travel. See page 116.

### ⚠ WARNING

Inadequate ground clearance could result in components contacting the ground, causing loss of control and serious injury or death. Always ensure ground clearance is at specification. See your dealer for service if you discover leaks or malfunction of any kind.

## REAR DRIVE BELT

### TIP

The drive belt system must be cool, clean and dry to accurately measure belt tension (deflection). Do not measure belt tension when the belt or drive system is wet or when it is hot (such as immediately after riding).

1. Check drive belt tension. See page 113.
2. Check the drive belt for debris.
3. Inspect drive belt condition. See page 111. If you discover cracks, broken teeth or frayed edges, replace the drive belt before riding. See the *INDIAN MOTORCYCLE Service Manual* or an authorized INDIAN MOTORCYCLE dealer can assist.

## FUEL LEVEL

For the most accurate reading, sit on the motorcycle and bring it to the upright position before turning it on.



Analog



Digital

The segments of the fuel gauge ① show the level of fuel in the fuel tank. When the last segment clears, a low fuel warning is activated. All segments including the fuel icon will flash. Refuel promptly.





## OPERATION OVERVIEW

The operation section of this manual describes how to ensure maximum performance and longevity through the proper care and operation of your motorcycle.

Important areas covered by the operation section include:

- Engine Break-In
- Fueling
- Starting the Engine
- Shifting Gears
- Using Cruise Control (if equipped)
- Accelerating
- Braking
- Stopping the Engine
- Parking

### TIP

Even if you're an experienced motorcycle operator or passenger, read all of the safety information in this manual before operating the motorcycle. See page 9.

## ENGINE BREAK-IN

The engine break-in period for your motorcycle is the first 500 miles (800 km) of operation. During this break-in period, critical engine parts require special wear-in procedures so they seat and mate properly. Read, understand and follow all break-in procedures to ensure the long-term performance and durability of your engine.

### NOTICE

Failure to properly follow the engine break-in procedures outlined in this manual can result in serious damage to the engine. Avoid full throttle operation and other conditions that may place an excessive load on the engine during the break-in period.

The more cautiously you treat your motorcycle during the break-in period, the more satisfied you will be with its performance later on. Overloading the engine at low RPM and/or running the engine prematurely at high RPM may result in damage to the pistons and/or other engine components.

Observe the following precautions during the break-in period:

- Upon initial start-up, do not allow the engine to idle for long periods as overheating can occur.
- Avoid fast starts with wide open throttle. Drive slowly until the engine warms up.
- Avoid running the engine at extremely low RPM in higher gears (lugging the engine).
- Drive within the recommended operating speeds and gears.

## OPERATION

### OPERATING SPEEDS AND GEARS

| ODOMETER |         | BREAK-IN PROCEDURE  |
|----------|---------|---|
| MILES    | KM      |   |
| 0-90     | 0-145   | Do not operate for extended periods above 1/3 throttle or at any one throttle position. Vary engine speed frequently.   |
| 91-300   | 146-483 | Do not operate for extended periods above 1/2 throttle or at any one throttle position. Vary engine speed frequently.   |
| 301-500  | 484-800 | Do not operate for extended periods above 3/4 throttle.   |
| At 500   | At 800  | Perform the break-in maintenance outlined in the maintenance section of this manual. Break-in maintenance should be performed by a dealership. Break-in maintenance must include inspection, adjustments, fastener tightening and an engine oil and filter change. Performing break-in maintenance at the required odometer reading helps ensure peak engine performance, minimal exhaust emissions and maximum service life of the engine. |

### FUELING

Always dismount the motorcycle and refuel on level ground with the sidestand down. Review the fuel warnings. Use only the recommended fuel. See page 175. Hold the nozzle while filling. Do not rest the weight of the nozzle and hose on the filler neck. Do not leave the nozzle unattended.

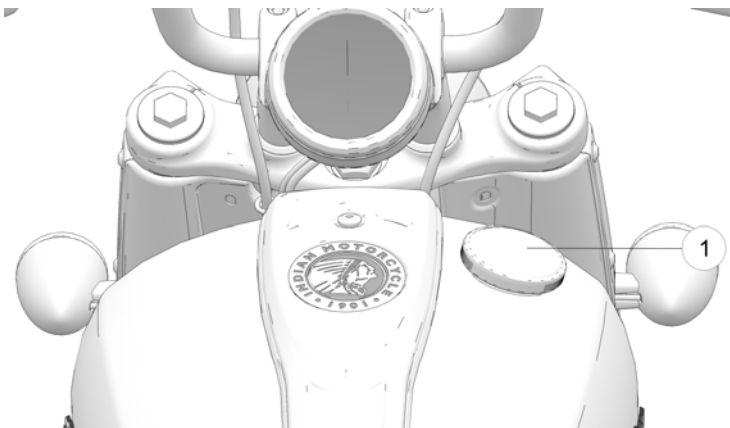

#### WARNING

Overflows or spilled gasoline could contact a hot engine or exhaust system and cause a fire, which could result in serious injury or death. Do not allow gasoline to contact hot components.

#### WARNING

Always remove the fuel cap slowly and fill the fuel tank slowly to prevent spillage. Do not overfill the fuel tank. Leave space in the tank to allow for the fuel to expand.

1. Turn the fuel cap ① counter-clockwise to remove it.

**NOTICE**

If the fuel cap is equipped with a tether, carefully rest fuel cap on the tank so that the rubber bumper is contacting the tank.

2. Insert the fuel nozzle into the fuel tank filler neck. The nozzle-stop at the bottom of the filler neck will prevent over-insertion.
3. Add fuel to the tank until it touches the bottom edge of the filler neck. The tank is full at this level.
4. Always securely install the fuel cap before remounting the motorcycle. To tighten the cap, turn it clockwise until the seal compresses onto the tank, then continue to tighten until the cap ratchets several times.

**NOTICE**

Fuel can damage painted surfaces and plastic parts. If gasoline spills on the any part of the motorcycle, immediately rinse it off with water or wipe it dry with a clean cloth.

## PRIMING THE FUEL SYSTEM

If the motorcycle runs out of fuel, prime the fuel system before attempting to restart the engine.

1. Fill the fuel tank.
2. Turn the power switch on.
3. Move the engine stop/run switch to the RUN position.
4. Allow the fuel pump to run until it stops (about 2 seconds).
5. Move the engine stop/run switch to the STOP position.
6. Repeat steps 3–5 five times.
7. Move the engine stop/run switch to the RUN position.
8. Start the engine.

## STARTING THE ENGINE

The starter interlock system allows the engine to be started only when the transmission is in neutral, or when the transmission is in gear with the clutch disengaged (clutch lever pulled in). The engine should NEVER start in any gear except neutral if the side-stand is down. See page 40.

**TIP**

If the motorcycle runs out of fuel, prime the system before attempting to restart the engine. See page 73.

## OPERATION

---

1. Perform the Pre-Ride Inspections. See page 61. Properly secure any cargo.
2. Straddle the motorcycle and bring it to the fully upright position. Retract the side-stand.

### TIP

For the electrical system to be activated with the power switch, the key fob must be within range. See page 28.

3. Move the engine stop/run switch to the RUN position.
4. Shift the transmission to neutral.
5. Apply the front brakes. Disengage the clutch (pull the clutch lever fully toward the handlebar).
6. The motorcycle will be electrically activated by pressing the power switch. Then with the throttle closed, press and release the starter switch to start the engine. The starter motor will crank until the engine starts, but no more than 3 seconds. If the engine does not start, wait five seconds and try again.
7. If starting a COOL engine, DO NOT open the throttle while starting. Idle speed is computer controlled and idle speed will adjust automatically depending on engine temperature and air temperature. Allow the engine to warm up for one minute minimum at low RPM after starting. Do not run the engine above 2500 RPM. If starting a WARM engine, DO NOT open the throttle while starting.

8. If either the check engine indicator or the low oil pressure indicator (or display) remains on after the engine starts, stop the engine *immediately*. Refer to the low oil pressure indicator/display information in the Low Oil Pressure Display section or the Indicator Lamps section.

### NOTICE

Operating an engine with a misfire or non-firing cylinder can overheat the catalytic converter, which could result in catalytic converter damage and loss of emission control. DO NOT OPERATE the motorcycle if a misfire or non-firing cylinder exists.

9. Leave the throttle closed and allow the engine to idle. Idle speed will gradually slow to normal as the engine warms to operating temperature.

### TIP

Do not rev the engine or put the transmission in gear immediately after starting the engine. Allow the engine to idle for about 30 seconds after a warm start or at least one minute after a cold start (longer in cold weather). This will allow oil to reach all areas before the engine is put under load.

### NOTICE

Do not run the engine at high RPM with the clutch disengaged or the transmission in neutral. Maximum safe engine speed is 5400 RPM. Never exceed the maximum safe RPM as this could result in serious engine damage.

## IDLE SHUT DOWN

If the motorcycle is left idling under normal conditions without user input for 15 minutes, the engine will shut down. If a misfire has been detected, the engine will shut down after 5 minutes without operator input. At any time during the idle countdown timer period, user input to the clutch/brake levers, or throttle, will end the shutdown sequence. At 3 minutes prior to engine shutdown, a notification will be provided to the user.

## SHIFTING GEARS

### WARNING

Forced shifting (without clutch lever pulled in) could cause damage to the engine, transmission and drive train. Such damage could cause loss of control, which could result in serious injury or death. Always pull the clutch lever fully toward the handlebars to disengage the clutch before shifting gears.

This motorcycle is equipped with a six-speed transmission. Neutral is located between first and second gear.

Press downward on the toe lever to shift to a lower gear. Lift upward on the toe lever to shift to a higher gear. Release the clutch lever after each gear shift.

Shifting to neutral is easiest if the motorcycle is rolling slowly. To shift from first gear to neutral, gently lift the toe lever a half stroke.

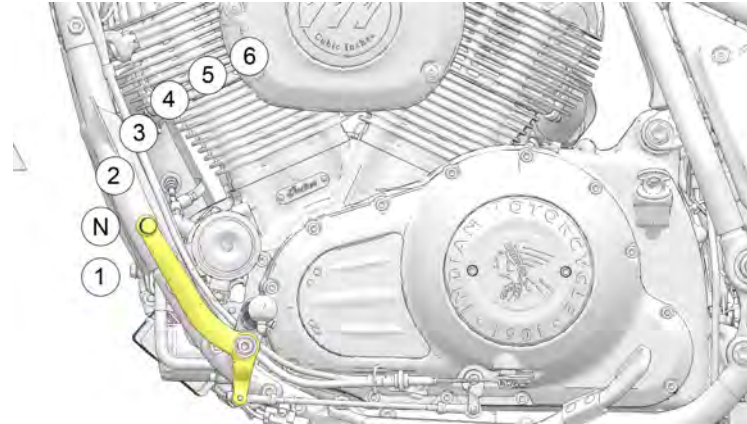

### TIP

The transmission is in neutral if you can move the motorcycle forward or rearward freely without disengaging the clutch. If the power switch is ON, the neutral indicator illuminates when the transmission is in neutral.

## SHIFTING GEARS WHILE STATIONARY

To locate neutral when the motorcycle is stationary, use one of the following techniques to load and unload the transmission:

## OPERATION

---

1. With the clutch disengaged (lever pulled inward), shift into neutral while rocking the motorcycle forward and rearward.
2. With the transmission in first gear, gently release the clutch until it just begins to engage. Apply upward pressure on the toe lever and quickly pull the clutch inward.

### NOTICE

There is a Neutral indicator light on the instrument cluster.

## SHIFTING GEARS WHILE DRIVING

1. Start the engine.
2. With the engine at idle speed, apply the front brakes.
3. Disengage the clutch (pull the clutch lever fully toward the handlebar).
4. Push the toe lever downward until you feel it stop in first gear.
5. Release the brake lever.
6. Simultaneously release the clutch lever while opening the throttle (rolling the throttle control grip rearward) in one smooth motion. As the clutch begins to engage, the motorcycle will move forward.

7. To shift to a higher gear, accelerate smoothly to the recommended shift point. See *Recommended Shift Points* chart. With a quick motion, simultaneously close the throttle completely and disengage the clutch. Raise the toe shift lever until you feel it stop at the next gear. Simultaneously release the clutch lever and open the throttle in one smooth motion.

### TIP

Within the recommended speed ranges (see Recommended Shift Points chart), you can downshift to slow the motorcycle or to increase power. You may want to downshift when climbing a hill or passing. Downshifting also helps to decrease speed when combined with closing the throttle.

8. To shift to a lower gear (downshift), simultaneously pull the clutch lever toward the handlebar and close the throttle. Move the toe shift lever downward until you feel it stop at the next gear. Simultaneously release the clutch lever while opening the throttle.

### WARNING

Downshifting improperly could cause transmission damage, loss of traction and loss of control, which could result in serious injury or death.

- Reduce speed before downshifting. Always downshift within the recommended shift points.
- Use extreme caution when downshifting on wet, slippery or other low traction surfaces. Release the clutch lever very gradually in these conditions.
- Avoid downshifting in a curve. Downshift before entering the curve.

## RECOMMENDED SHIFT POINTS

### UPSHIFTING (ACCELERATING)

| GEAR CHANGE | RECOMMENDED SPEED |
|-------------|-------------------|
| 1 to 2      | 15 MPH (24 km/h)  |
| 2 to 3      | 25 MPH (40 km/h)  |
| 3 to 4      | 35 MPH (56 km/h)  |
| 4 to 5      | 45 MPH (72 km/h)  |
| 5 to 6      | 50 MPH (80 km/h)  |

### DOWNSHIFTING (DECELERATING)

| GEAR CHANGE | RECOMMENDED SPEED |
|-------------|-------------------|
| 6 to 5      | 40 MPH (64 km/h)  |
| 5 to 4      | 35 MPH (56 km/h)  |
| 4 to 3      | 25 MPH (40 km/h)  |

| GEAR CHANGE | RECOMMENDED SPEED |
|-------------|-------------------|
| 3 to 2      | 15 MPH (24 km/h)  |
| 2 to 1      | 10 MPH (16 km/h)  |

## BRAKING

Always allow sufficient stopping distance so that brakes can be applied gradually.

### NOTICE

Applying slightly more front brake than rear brake generally provides the best braking performance.

## OPERATION

1. To slow the motorcycle with the brakes, close the throttle and apply the front and rear brakes evenly and gradually.

### NOTICE

If the anti-lock brakes engage during a braking event, the rider will feel pulsing at the brake levers. Continue to apply steady pressure to the brakes for the best stopping performance.

2. As the motorcycle slows, disengage the clutch, or downshift each time vehicle speed reaches a downshift point.

### ⚠ WARNING

Braking improperly could result in loss of control, which could result in serious injury or death. Avoid braking abruptly. Always apply the brakes gradually, especially on wet, slippery or other low traction surfaces. Avoid braking in a curve or turn. Bring the motorcycle to the upright position before applying the brakes.

## ACCELERATING

Accelerate by opening the throttle (rolling the throttle control grip rearward). For even acceleration, open the throttle with a smooth, continuous motion. When you reach the recommended speed for upshifting, shift up one gear.

### ⚠ WARNING

Accelerating abruptly could cause your body to shift rearward suddenly, which could result in loss of control. Accelerating abruptly could also cause loss of control on low traction surfaces. Loss of control could result in serious injury or death. Always accelerate gradually, especially on wet, slippery or other low traction surfaces.

## STOPPING THE ENGINE

Before stopping the engine, bring the motorcycle to a complete stop. Shift to neutral or disengage the clutch.

### ⚠ WARNING

Stopping the engine with the transmission in gear while the motorcycle is moving could cause loss of rear wheel traction or engine and transmission damage, which could cause loss of control and serious injury or death. Always stop the engine after the motorcycle is fully stopped and the transmission is in neutral. If the engine stops unexpectedly while the motorcycle is moving, guide the motorcycle to a safe location off the road and away from traffic. Turn the power switch off.

1. When fully stopped, shift into neutral.
2. Move the engine stop/run switch to the STOP position.
3. Turn the power switch off.



## USING CRUISE CONTROL

The cruise control switches are located on the right handlebar. Read this section and understand how to safely operate this feature before using the cruise control.

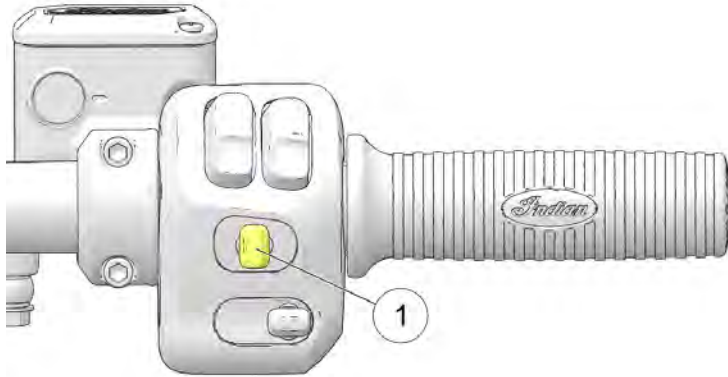

Cruise control can be activated and adjusted from the right control using the Cruise Control Switch ①.

| Toggle Position | Function          |
|-----------------|-------------------|
| Left            | Set/Decelerate    |
| Center          | Off/On            |
| Right           | Resume/Accelerate |

### WARNING

Improper operation of cruise control could cause loss of control and result in serious injury or death. Follow all cruise operation procedures carefully. Never use cruise control when roads are wet or slippery. Do not use cruise control when riding in heavy or congested traffic.

## CRUISE CONTROL TIPS

- Cruise control can be set in gears 3-6.
- Vehicle speed must be above 20 MPH (32 km/h).
- Set speed will vary slightly in hilly terrain.
- Cruise control will not resume a pre-set speed if the resulting acceleration or deceleration rate is too high or too low. For example, resuming a set speed of 70 MPH from 40 MPH (64 km/h), while in 6th gear, may cause cruise to disengage.
- Cruise control will not engage if brake lights are not operating properly.
- The clutch or either brake must have been activated at least once since the engine was started for the cruise control to function.

## OPERATION

---

### SET SPEED

1. Press and release the center of the cruise control switch ①. The amber cruise control indicator will illuminate in the instrument cluster. Cruise control is enabled, but not set.
2. Accelerate to the desired speed and press left on the cruise control switch to activate cruise control. The green cruise control indicator lamp will illuminate. Cruise control is set to the desired speed.

### RESUME SPEED

After disengaging the cruise control with the brake, throttle or clutch, press right on the cruise control switch to return to the set speed.

### ACCELERATE

While cruise control is engaged, tap right on the cruise control switch to increase speed in approximately 1 MPH (1-2 km/h) increments. Press and hold the right on the cruise control switch to accelerate to a new set speed (resets when switch is released).

#### NOTICE

If you use the throttle to accelerate and then release it, the cruise control will resume the previously set speed.

### DECELERATE

While cruise control is engaged, tap and release left on the cruise control switch to decrease speed in approximately 1 MPH (1-2 km/h) increments. Press and hold left on the cruise control switch to decelerate to a new set speed (resets when switch is released), or to the minimum cruise speed of 20 MPH (32 km/h).

### CANCEL CRUISE CONTROL

To temporarily cancel the cruise control and allow use of the resume feature:

- Apply the brakes, or
- Pull the clutch lever in, or
- Roll the throttle grip forward past the idle position

To cancel the cruise control and erase the set speed from memory, press the cruise on/off switch.

### PARKING

Choose a firm level surface to park the motorcycle.

1. When fully stopped, shift into neutral.
2. Stop the engine.
3. Fully extend the sidestand.
4. Turn the handlebars to the left and lean the motorcycle to the left until the sidestand firmly supports the motorcycle.
5. Turn the power switch off and ensure the run/stop switch on the right-hand control is in the *off* position.

---

## PARKING ON A SLOPE

If parking on a slope is unavoidable, park with the front wheel uphill from the rear wheel. Place the transmission in first gear and position the motorcycle so that it is stable when it rests on the sidestand.

## PARKING ON A SOFT SURFACE

If parking on a soft surface is unavoidable, place a sidestand footrest under the foot of the sidestand to provide a firm surface. The sidestand footrest must be strong enough and large enough to support the motorcycle's weight without sinking into the parking surface.

Asphalt becomes soft in hot weather. A sidestand can sink into soft asphalt and the motorcycle may fall. When parking on asphalt in hot weather, use a sidestand footrest.



Hot engine and exhaust components can cause burns to skin and can ignite a fire if exposed to flammable materials. Always park the motorcycle clear of flammable materials and where people are not likely to contact hot components.



## MAINTENANCE

### SAFETY DURING SERVICE PROCEDURES



Failure to follow all recommended precautions and procedures could result in serious injury or death. Always heed all safety precautions and follow all operation, inspection and maintenance procedures outlined in this manual.

- Improperly installed or adjusted components can make the motorcycle unstable or hard to handle. Improperly installed electrical components can cause engine or electrical system failure. In either event, damage or serious injury could result. If you do not have the time, tools and expertise necessary to complete a procedure properly, please see your dealer for service.
- Review the safety-related maintenance information in the Safety Maintenance section.
- Before beginning any maintenance procedure, read the instructions for the entire procedure.
- Always position the motorcycle on a firm level surface before performing service. Make sure the motorcycle will not tip or fall while elevated or while on the sidestand. See the Elevating the Vehicle section for details.
- Hot engine and exhaust components can cause burns to skin and can ignite a fire if exposed to flammable materials. Always park the motorcycle clear of flammable materials and where people are not likely to contact hot components.
- Wear eye and face protection when using pressurized air.
- Never start the engine or let it run in an enclosed area. Engine exhaust fumes are poisonous and can cause loss of consciousness or death in a short time.
- During some procedures you may use potentially hazardous products such as oil or brake fluid. Always follow the instructions and warnings on the product packaging.

## MAINTENANCE

---

### ROAD TESTS

Before returning the motorcycle to regular use after performing service, road test it in a safe environment. Pay special attention to the proper fit and operation of all serviced components. Make any corrections or additional adjustments necessary to ensure safe vehicle performance.

### MAJOR MAINTENANCE

Major repairs typically require technical skills and specially designed tools. Emission system service requires special tools and training and should be performed by your dealer. See the *INDIAN MOTORCYCLE Service Manual* or an authorized INDIAN MOTORCYCLE dealer or other qualified dealer.

### BREAK-IN MAINTENANCE

Perform the break-in maintenance procedures when the motorcycle's odometer registers 500 miles (800 km). Please see your authorized dealer for this service.

Performing the break-in maintenance will help ensure optimum engine performance for the entire service life of the engine. Your dealer will change engine oil, inspect all fluids and serviceable components, ensure that all fasteners are tightened and make other adjustments as needed.

### PERIODIC MAINTENANCE

Inspect, clean, lubricate, adjust and replace parts as necessary. When inspection reveals the need for replacement parts, use genuine INDIAN MOTORCYCLE parts available from your dealer. Record service and maintenance information on page 189.

#### NOTICE

Use of non-recommended lubricants and components can result in damage to the motorcycle. Damage resulting from the use of non-recommended products is not covered by warranty.

Perform maintenance at the intervals specified in the following maintenance interval charts. *Vehicles subjected to severe use must be inspected and serviced more frequently.*

### SEVERE USE DEFINITION

- high speed operation for extended periods
- low speed operation for extended periods
- operation in dusty or otherwise adverse conditions
- operation in cold weather (temperatures below freezing)

## MAINTENANCE INTERVALS

The maintenance interval charts outline required maintenance and inspection based on vehicle miles. Each table states the number of miles that service is required on the vehicle. Some items or components may need to be serviced more often due to severe use. When the vehicle goes beyond 50,000 miles, return to the 500 mile chart and start the interval process over.

### KEY

XU - Perform these procedures more often for vehicles subjected to severe use.

D - Have an authorized Indian Motorcycle dealer perform these services.

E - Emission Control System Service (California / International)

### 500 MILE (800 KM) SERVICE

| ITEM |                                     | REMARKS   |
|------|-------------------------------------|---|
| D    | Crankcase Ventilation System        | Inspect; tighten, clean, adjust   |
| D    | Drive Belt                          | Inspect; tighten, clean, adjust   |
|      | Damper, Cushion Drive               | Visual inspection for cracks or deformation is required whenever the rear wheel is removed. Replace if damage is found. |
| D    | Engine Mount Fasteners              | Inspect; tighten, adjust  |
| XU   | Engine Oil & Filter Change          | Change oil and filter, inspect used oil for contaminants  |
| E    | Evaporative Emission Control System | Inspect; clean  |
| E    | Exhaust System                      | Inspect; tighten, adjust  |
| D    | Fuel System                         | Inspect; clean  |
|      | Key Fob Battery                     | Replace at specified interval or every 2 years  |
| D    | Oil Lines / Oil System Inspection   | Inspect; clean, adjust if necessary   |

## MAINTENANCE

| ITEM   |   | REMARKS  |
|--------|---|--|
|        | Battery                                 | Check terminals; clean; test                                     |
| D      | Brake Fluid                             | Change every two years (DOT 4)                                   |
| XU / D | Brake Pads                              | Inspect pad wear; replace if worn beyond service limit           |
| D      | Clutch Lever                            | Lubricate with proper lubricant as directed                      |
| D      | Clutch Cable Freeplay                   | Inspect; adjust if necessary                                     |
| D      | Control Cable Ends, Pinion Shaft Clevis | Inspect; lubricate with proper lubricant as directed             |
| D      | Fasteners                               | Inspect; tighten if necessary                                    |
| D      | Front Brake Lever                       | Adjust if necessary, lubricate with proper lubricant as directed |
| D      | Front Fork Oil                          | Inspect  |
| D      | Front Forks and Front Axle              | Inspect; adjust if necessary                                     |
| D      | Gear Shift Pedal                        | Inspect; adjust if necessary                                     |
| D      | Head Light                              | Inspect; adjust if necessary                                     |
| D      | Rear Brake Pedal                        | Inspect; adjust if necessary                                     |
| D      | Rear Shock Absorber                     | Inspect; adjust if necessary                                     |
| D      | Rear Wheel Alignment                    | Inspect; adjust if necessary                                     |
|        | Road Test                               | Perform Road Test  |
| D      | Sidestand                               | Lubricate with proper lubricant as directed                      |
| D      | Steering Bearings                       | Inspect  |
| D      | Suspension Linkage, Rear                | Inspect  |



| ITEM |                         | REMARKS   |
|------|-------------------------|---|
| D    | Swing Arm and Rear Axle | Inspect   |
| D    | Tires / Wheels          | Inspect tread depth, sidewall cracking, wear patterns |

## 2,500 MILE (4,000 KM) SERVICE

| ITEM   |                                     | REMARKS   |
|--------|-------------------------------------|---|
| XU     | Air Filter                          | Inspect; clean  |
| D      | Crankcase Ventilation System        | Inspect; tighten, clean, adjust   |
|        | Damper, Cushion Drive               | Visual inspection for cracks or deformation is required whenever the rear wheel is removed. Replace if damage is found. |
| D      | Drive Belt                          | Inspect; tighten, clean, adjust   |
| E      | Evaporative Emission Control System | Inspect; clean  |
| E      | Exhaust System                      | Inspect; tighten, adjust  |
| D      | Fuel System                         | Inspect; clean  |
| D      | Oil Lines / Oil System Inspection   | Inspect; clean, adjust if necessary   |
|        | Battery                             | Check terminals; clean; test  |
| D      | Brake Fluid                         | Change every two years (DOT 4)  |
| XU / D | Brake Pads                          | Inspect pad wear; replace if worn beyond service limit  |
| D      | Clutch Cable Freeplay               | Inspect; adjust if necessary  |
| D      | Fasteners                           | Inspect; tighten if necessary   |
| D      | Front Brake Lever                   | Inspect; adjust if necessary, lubricate with proper lubricant as directed   |

## MAINTENANCE

| ITEM |                            | REMARKS   |
|------|----------------------------|---|
| D    | Front Forks and Front Axle | Inspect; adjust if necessary  |
| D    | Gear Shift Pedal           | Inspect; adjust if necessary  |
| D    | Head Light                 | Inspect; adjust if necessary  |
| D    | Rear Brake Pedal           | Inspect; adjust if necessary  |
| D    | Rear Shock Absorber        | Inspect; adjust if necessary  |
| D    | Rear Wheel Alignment       | Inspect; adjust if necessary  |
|      | Road Test                  | Perform Road Test   |
| D    | Sidestand                  | Inspect; adjust if necessary, lubricate with proper lubricant as directed |
| D    | Steering Bearings          | Inspect   |
| D    | Suspension Linkage, Rear   | Inspect   |
| D    | Swing Arm and Rear Axle    | Inspect   |
| D    | Tires / Wheels             | Inspect tread depth, sidewall cracking, wear patterns                     |

## 5,000 MILE (8,000 KM) SERVICE

| ITEM |                              | REMARKS   |
|------|------------------------------|---|
| XU   | Air Filter                   | Inspect; clean  |
| D    | Crankcase Ventilation System | Inspect; tighten, clean, adjust   |
|      | Damper, Cushion Drive        | Visual inspection for cracks or deformation is required whenever the rear wheel is removed. Replace if damage is found. |
| D    | Drive Belt                   | Inspect; tighten, clean, adjust   |

| ITEM   |   | REMARKS  |
|--------|---|--|
| XU     | Engine Oil & Filter Change              | Change oil and filter, inspect used oil for contaminants         |
| E      | Evaporative Emission Control System     | Inspect; clean   |
| E      | Exhaust System                          | Inspect; tighten, adjust   |
| D      | Fuel System                             | Inspect; clean   |
| D      | Oil Lines / Oil System Inspection       | Inspect; clean, adjust if necessary                              |
|        | Battery                                 | Check terminals; clean; test                                     |
| D      | Brake Fluid                             | Change every two years (DOT 4)                                   |
| XU / D | Brake Pads                              | Inspect pad wear; replace if worn beyond service limit           |
| D      | Clutch Lever                            | Inspect; adjust if necessary                                     |
| D      | Clutch Cable Freeplay                   | Inspect; adjust if necessary                                     |
| D      | Control Cable Ends, Pinion Shaft Clevis | Inspect; lubricate with proper lubricant as directed             |
| D      | Fasteners                               | Inspect; tighten if necessary                                    |
| D      | Front Brake Lever                       | Adjust if necessary, lubricate with proper lubricant as directed |
| D      | Front Fork Oil                          | Replace at specified interval or every 2 years                   |
| D      | Front Forks and Front Axle              | Inspect; adjust if necessary                                     |
| D      | Gear Shift Pedal                        | Inspect; adjust if necessary                                     |
| D      | Rear Brake Pedal                        | Inspect; adjust if necessary                                     |
| D      | Rear Shock Absorber                     | Inspect; adjust if necessary                                     |
| D      | Rear Wheel Alignment                    | Inspect; adjust if necessary                                     |
|        | Road Test                               | Perform Road Test  |

## MAINTENANCE

| ITEM |                          | REMARKS   |
|------|--------------------------|---|
| D    | Sidestand                | Inspect; adjust if necessary, lubricate with proper lubricant as directed |
| D    | Steering Bearings        | Inspect   |
| D    | Suspension Linkage, Rear | Inspect   |
| D    | Swing Arm and Rear Axle  | Inspect   |
| D    | Tires / Wheels           | Inspect tread depth, sidewall cracking, wear patterns                     |

## 10,000 MILE (16,000 KM) SERVICE

| ITEM  |                                     | REMARKS   |
|-------|-------------------------------------|---|
| XU    | Air Filter                          | Replace   |
| D     | Crankcase Ventilation System        | Inspect; tighten, clean, adjust   |
|       | Damper, Cushion Drive               | Visual inspection for cracks or deformation is required whenever the rear wheel is removed. Replace if damage is found. |
| D     | Drive Belt                          | Inspect; tighten, clean, adjust   |
| D     | Engine Compression                  | Inspect; correct if necessary   |
| XU    | Engine Oil & Filter Change          | Change oil and filter, inspect used oil for contaminants  |
| E     | Evaporative Emission Control System | Inspect; clean  |
| E     | Exhaust System                      | Inspect; tighten, adjust  |
| D     | Fuel System                         | Inspect; clean  |
| D     | Oil Lines / Oil System Inspection   | Inspect; clean, adjust if necessary   |
| D / E | Spark Plugs                         | Inspect; torque to specification  |

| ITEM   |   | REMARKS  |
|--------|---|--|
|        | Battery                                 | Check terminals; clean; test                                     |
| D      | Brake Fluid                             | Replace (DOT 4)  |
| XU / D | Brake Pads                              | Inspect pad wear; replace if worn beyond service limit           |
| D      | Clutch Lever                            | Lubricate with proper lubricant as directed                      |
| D      | Clutch Cable Freeplay                   | Inspect; adjust if necessary                                     |
| D      | Control Cable Ends, Pinion Shaft Clevis | Lubricate with proper lubricant as directed                      |
| D      | Fasteners                               | Inspect; tighten if necessary                                    |
| D      | Front Brake Lever                       | Adjust if necessary, lubricate with proper lubricant as directed |
| D      | Front Fork Oil                          | Replace at specified interval or every 2 years                   |
| D      | Front Forks and Front Axle              | Inspect; adjust if necessary                                     |
| D      | Gear Shift Pedal                        | Inspect; adjust if necessary                                     |
| D      | Gear Position Switch                    | Inspect; clean.  |
| D      | Head Light                              | Inspect; adjust if necessary                                     |
| D      | Rear Brake Pedal                        | Inspect; adjust if necessary                                     |
| D      | Rear Shock Absorber                     | Inspect; adjust if necessary                                     |
| D      | Rear Wheel Alignment                    | Inspect; adjust if necessary                                     |
|        | Road Test                               | Perform Road Test  |
| D      | Sidestand                               | Lubricate with proper lubricant as directed                      |
| D      | Steering Bearings                       | Inspect  |
| D      | Suspension Linkage, Rear                | Inspect  |

## MAINTENANCE

| ITEM |                         | REMARKS   |
|------|-------------------------|---|
| D    | Swing Arm and Rear Axle | Inspect   |
| D    | Tires / Wheels          | Inspect tread depth, sidewall cracking, wear patterns |

## 15,000 MILE (24,000 KM) SERVICE

| ITEM   |                                     | REMARKS   |
|--------|-------------------------------------|---|
| XU     | Air Filter                          | Replace   |
| D      | Crankcase Ventilation System        | Inspect; tighten, clean, adjust   |
|        | Damper, Cushion Drive               | Visual inspection for cracks or deformation is required whenever the rear wheel is removed. Replace if damage is found. |
| D      | Drive Belt                          | Inspect; tighten, clean, adjust   |
| XU     | Engine Oil & Filter Change          | Change oil and filter, inspect used oil for contaminants  |
| E      | Evaporative Emission Control System | Inspect; clean  |
| E      | Exhaust System                      | Inspect; tighten, adjust  |
| D      | Fuel System                         | Inspect; clean  |
| D      | Oil Lines / Oil System Inspection   | Inspect; clean, adjust if necessary   |
|        | Battery                             | Check terminals; clean; test  |
| D      | Brake Fluid                         | Change every two years (DOT 4)  |
| XU / D | Brake Pads                          | Inspect pad wear; replace if worn beyond service limit  |
| D      | Clutch Lever                        | Inspect; adjust if necessary  |
| D      | Clutch Cable Freeplay               | Inspect; adjust if necessary  |

| ITEM |                            | REMARKS   |
|------|----------------------------|---|
| D    | Control Cable Ends         | Inspect; adjust if necessary  |
| D    | Fasteners                  | Inspect; tighten if necessary   |
| D    | Front Brake Lever          | Adjust if necessary, lubricate with proper lubricant as directed          |
| D    | Front Fork Oil             | Replace   |
| D    | Front Forks and Front Axle | Inspect; adjust if necessary  |
| D    | Gear Shift Pedal           | Inspect; adjust if necessary  |
| D    | Rear Brake Pedal           | Inspect; adjust if necessary  |
| D    | Rear Shock Absorber        | Inspect; adjust if necessary  |
| D    | Rear Wheel Alignment       | Inspect; adjust if necessary  |
|      | Road Test                  | Perform Road Test   |
| D    | Sidestand                  | Inspect; adjust if necessary, lubricate with proper lubricant as directed |
| D    | Steering Bearings          | Inspect   |
| D    | Suspension Linkage, Rear   | Inspect   |
| D    | Swing Arm and Rear Axle    | Inspect   |
| D    | Tires / Wheels             | Inspect tread depth, sidewall cracking, wear patterns                     |

**20,000 MILE (32,000 KM) SERVICE**

| ITEM |                              | REMARKS                         |
|------|------------------------------|---------------------------------|
| XU   | Air Filter                   | Inspect; clean                  |
| D    | Crankcase Ventilation System | Inspect; tighten, clean, adjust |

## MAINTENANCE

| ITEM   |   | REMARKS   |
|--------|---|---|
|        | Damper, Cushion Drive                   | Visual inspection for cracks or deformation is required whenever the rear wheel is removed. Replace if damage is found. |
| D      | Drive Belt                              | Inspect; tighten, clean, adjust   |
| D      | Engine Compression                      | Inspect; correct if necessary   |
| XU     | Engine Oil & Filter Change              | Change oil and filter, inspect used oil for contaminants  |
| E      | Evaporative Emission Control System     | Inspect; clean  |
| E      | Exhaust System                          | Inspect; tighten, adjust  |
| D      | Fuel System                             | Inspect; clean  |
|        | Key Fob Battery                         | Replace   |
| D      | Oil Lines / Oil System Inspection       | Inspect; clean, adjust if necessary   |
| D / E  | Spark Plugs                             | Inspect; torque to specification  |
|        | Battery                                 | Check terminals; clean; test  |
| D      | Brake Fluid                             | Replace (DOT 4)   |
| XU / D | Brake Pads                              | Inspect pad wear; replace if worn beyond service limit  |
| D      | Clutch Lever                            | Lubricate with proper lubricant as directed   |
| D      | Clutch Cable Freeplay                   | Inspect; adjust if necessary  |
| D      | Control Cable Ends, Pinion Shaft Clevis | Lubricate with proper lubricant as directed   |
| D      | Fasteners                               | Inspect; tighten if necessary   |
| D      | Front Brake Lever                       | Adjust if necessary, lubricate with proper lubricant as directed  |
| D      | Front Fork Oil                          | Inspect   |



| ITEM |                            | REMARKS   |
|------|----------------------------|---|
| D    | Front Forks and Front Axle | Inspect; adjust if necessary                          |
| D    | Gear Shift Pedal           | Inspect; adjust if necessary                          |
| D    | Gear Position Switch       | Inspect; clean.                                       |
| D    | Head Light                 | Inspect; adjust if necessary                          |
| D    | Rear Brake Pedal           | Inspect; adjust if necessary                          |
| D    | Rear Shock Absorber        | Inspect; adjust if necessary                          |
| D    | Rear Wheel Alignment       | Inspect; adjust if necessary                          |
|      | Road Test                  | Perform Road Test                                     |
| D    | Sidestand                  | Lubricate with proper lubricant as directed           |
| D    | Steering Bearings          | Inspect   |
| D    | Suspension Linkage, Rear   | Inspect   |
| D    | Swing Arm and Rear Axle    | Inspect   |
| D    | Tires / Wheels             | Inspect tread depth, sidewall cracking, wear patterns |

**25,000 MILE (40,000 KM) SERVICE**

| ITEM |                              | REMARKS   |
|------|------------------------------|---|
| XU   | Air Filter                   | Inspect; clean  |
| D    | Crankcase Ventilation System | Inspect; tighten, clean, adjust   |
|      | Damper, Cushion Drive        | Visual inspection for cracks or deformation is required whenever the rear wheel is removed. Replace if damage is found. |

## MAINTENANCE

| ITEM   |                                     | REMARKS  |
|--------|-------------------------------------|--|
| D      | Drive Belt                          | Inspect; tighten, clean, adjust                                  |
| XU     | Engine Oil & Filter Change          | Change oil and filter, inspect used oil for contaminants         |
| E      | Evaporative Emission Control System | Inspect; clean   |
| E      | Exhaust System                      | Inspect; tighten, adjust   |
| D      | Fuel System                         | Inspect; clean   |
| D      | Oil Lines / Oil System Inspection   | Inspect; clean, adjust if necessary                              |
|        | Battery                             | Check terminals; clean; test                                     |
| D      | Brake Fluid                         | Change every two years (DOT 4)                                   |
| XU / D | Brake Pads                          | Inspect pad wear; replace if worn beyond service limit           |
| D      | Clutch Lever                        | Inspect; adjust if necessary                                     |
| D      | Clutch Cable Freeplay               | Inspect; adjust if necessary                                     |
| D      | Control Cable Ends                  | Inspect; adjust if necessary                                     |
| D      | Fasteners                           | Inspect; tighten if necessary                                    |
| D      | Front Brake Lever                   | Adjust if necessary, lubricate with proper lubricant as directed |
| D      | Front Fork Oil                      | Inspect  |
| D      | Front Forks and Front Axle          | Inspect; adjust if necessary                                     |
| D      | Gear Shift Pedal                    | Inspect; adjust if necessary                                     |
| D      | Rear Brake Pedal                    | Inspect; adjust if necessary                                     |
| D      | Rear Shock Absorber                 | Inspect; adjust if necessary                                     |
| D      | Rear Wheel Alignment                | Inspect; adjust if necessary                                     |

| ITEM |                          | REMARKS   |
|------|--------------------------|---|
|      | Road Test                | Perform Road Test   |
| D    | Sidestand                | Inspect; adjust if necessary, lubricate with proper lubricant as directed |
| D    | Steering Bearings        | Inspect   |
| D    | Suspension Linkage, Rear | Inspect   |
| D    | Swing Arm and Rear Axle  | Inspect   |
| D    | Tires / Wheels           | Inspect tread depth, sidewall cracking, wear patterns                     |

### 30,000 MILE (48,000 KM) SERVICE

| ITEM |                                     | REMARKS   |
|------|-------------------------------------|---|
| XU   | Air Filter                          | Replace   |
| D    | Crankcase Ventilation System        | Inspect; tighten, clean, adjust   |
|      | Damper, Cushion Drive               | Visual inspection for cracks or deformation is required whenever the rear wheel is removed. Replace if damage is found. |
| D    | Drive Belt                          | Replace   |
| D    | Engine Compression                  | Inspect; correct if necessary   |
| XU   | Engine Oil & Filter Change          | Change oil and filter, inspect used oil for contaminants  |
| E    | Evaporative Emission Control System | Inspect; clean  |
| E    | Exhaust System                      | Inspect; tighten, adjust  |
| D    | Fuel System                         | Inspect; clean  |
| D    | Oil Lines / Oil System Inspection   | Inspect; clean, adjust if necessary   |

## MAINTENANCE

| ITEM   |   | REMARKS  |
|--------|---|--|
| D / E  | Spark Plugs                             | Replace  |
|        | Battery                                 | Check terminals; clean; test                           |
| D      | Brake Fluid                             | Replace (DOT 4)  |
| XU / D | Brake Pads                              | Inspect pad wear; replace if worn beyond service limit |
| D      | Clutch Lever                            | Lubricate with proper lubricant as directed            |
| D      | Clutch Cable Freeplay                   | Inspect; adjust if necessary                           |
| D      | Control Cable Ends, Pinion Shaft Clevis | Lubricate with proper lubricant as directed            |
| D      | Fasteners                               | Inspect; tighten if necessary                          |
| D      | Front Brake Lever                       | Lubricate with proper lubricant as directed            |
| D      | Front Fork Oil                          | Replace  |
| D      | Front Forks and Front Axle              | Inspect; adjust if necessary                           |
| D      | Gear Shift Pedal                        | Inspect; adjust if necessary                           |
| D      | Gear Position Switch                    | Inspect; clean.  |
| D      | Head Light                              | Inspect; adjust if necessary                           |
| D      | Rear Brake Pedal                        | Inspect; adjust if necessary                           |
| D      | Rear Shock Absorber                     | Inspect; adjust if necessary                           |
| D      | Rear Wheel Alignment                    | Inspect; adjust if necessary                           |
|        | Road Test                               | Perform Road Test                                      |
| D      | Sidestand                               | Lubricate with proper lubricant as directed            |
| D      | Steering Bearings                       | Inspect  |

| ITEM |                          | REMARKS   |
|------|--------------------------|---|
| D    | Suspension Linkage, Rear | Inspect   |
| D    | Swing Arm and Rear Axle  | Inspect   |
| D    | Tires / Wheels           | Inspect tread depth, sidewall cracking, wear patterns |

### 35,000 MILE (52,000 KM) SERVICE

| ITEM   |                                     | REMARKS   |
|--------|-------------------------------------|---|
| XU     | Air Filter                          | Inspect; clean  |
| D      | Crankcase Ventilation System        | Inspect; tighten, clean, adjust   |
|        | Damper, Cushion Drive               | Visual inspection for cracks or deformation is required whenever the rear wheel is removed. Replace if damage is found. |
| D      | Drive Belt                          | Inspect; tighten, clean, adjust   |
| XU     | Engine Oil & Filter Change          | Change oil and filter, inspect used oil for contaminants  |
| E      | Evaporative Emission Control System | Inspect; clean  |
| E      | Exhaust System                      | Inspect; tighten, adjust  |
| D      | Fuel System                         | Inspect; clean  |
| D      | Oil Lines / Oil System Inspection   | Inspect; clean, adjust if necessary   |
|        | Battery                             | Check terminals; clean; test  |
| D      | Brake Fluid                         | Change every two years (DOT 4)  |
| XU / D | Brake Pads                          | Inspect pad wear; replace if worn beyond service limit  |
| D      | Clutch Lever                        | Inspect; adjust if necessary  |

## MAINTENANCE

| ITEM |                            | REMARKS  |
|------|----------------------------|--|
| D    | Clutch Cable Freeplay      | Inspect; adjust if necessary                                     |
| D    | Control Cable Ends         | Inspect; adjust if necessary                                     |
| D    | Fasteners                  | Inspect; tighten if necessary                                    |
| D    | Front Brake Lever          | Adjust if necessary, lubricate with proper lubricant as directed |
| D    | Front Fork Oil             | Inspect  |
| D    | Front Forks and Front Axle | Inspect; adjust if necessary                                     |
| D    | Gear Shift Pedal           | Inspect; adjust if necessary                                     |
| D    | Rear Brake Pedal           | Inspect; adjust if necessary                                     |
| D    | Rear Shock Absorber        | Inspect; adjust if necessary                                     |
| D    | Rear Wheel Alignment       | Inspect; adjust if necessary                                     |
|      | Road Test                  | Perform Road Test  |
| D    | Sidestand                  | Lubricate with proper lubricant as directed                      |
| D    | Steering Bearings          | Inspect  |
| D    | Suspension Linkage, Rear   | Inspect  |
| D    | Swing Arm and Rear Axle    | Inspect  |
| D    | Tires / Wheels             | Inspect tread depth, sidewall cracking, wear patterns            |

**40,000 MILE (64,000 KM) SERVICE**

| ITEM   |   | REMARKS   |
|--------|---|---|
| XU     | Air Filter                              | Inspect; clean  |
| D      | Crankcase Ventilation System            | Inspect; tighten, clean, adjust   |
|        | Damper, Cushion Drive                   | Visual inspection for cracks or deformation is required whenever the rear wheel is removed. Replace if damage is found. |
| D      | Drive Belt                              | Inspect; tighten, clean, adjust   |
| D      | Engine Compression                      | Inspect; correct if necessary   |
| XU     | Engine Oil & Filter Change              | Change oil and filter, inspect used oil for contaminants  |
| E      | Evaporative Emission Control System     | Inspect; clean  |
| E      | Exhaust System                          | Inspect; tighten, adjust  |
| D      | Fuel System                             | Inspect; clean  |
|        | Key Fob Battery                         | Replace   |
| D      | Oil Lines / Oil System Inspection       | Inspect; clean, adjust if necessary   |
| D / E  | Spark Plugs                             | Inspect; torque to specification  |
|        | Battery                                 | Check terminals; clean; test  |
| D      | Brake Fluid                             | Replace (DOT 4)   |
| XU / D | Brake Pads                              | Inspect pad wear; replace if worn beyond service limit  |
| D      | Clutch Lever                            | Lubricate with proper lubricant as directed   |
| D      | Clutch Cable Freeplay                   | Inspect; adjust if necessary  |
| D      | Control Cable Ends, Pinion Shaft Clevis | Lubricate with proper lubricant as directed   |

## MAINTENANCE

| ITEM |                            | REMARKS  |
|------|----------------------------|--|
| D    | Fasteners                  | Inspect; tighten if necessary                                    |
| D    | Front Brake Lever          | Adjust if necessary, lubricate with proper lubricant as directed |
| D    | Front Fork Oil             | Inspect  |
| D    | Front Forks and Front Axle | Inspect; adjust if necessary                                     |
| D    | Gear Shift Pedal           | Inspect; adjust if necessary                                     |
| D    | Gear Position Switch       | Inspect; clean.  |
| D    | Head Light                 | Inspect; adjust if necessary                                     |
| D    | Rear Brake Pedal           | Inspect; adjust if necessary                                     |
| D    | Rear Shock Absorber        | Inspect; adjust if necessary                                     |
| D    | Rear Wheel Alignment       | Inspect; adjust if necessary                                     |
|      | Road Test                  | Perform Road Test  |
| D    | Sidestand                  | Lubricate with proper lubricant as directed                      |
| D    | Steering Bearings          | Inspect  |
| D    | Suspension Linkage, Rear   | Inspect  |
| D    | Swing Arm and Rear Axle    | Inspect  |
| D    | Tires / Wheels             | Inspect tread depth, sidewall cracking, wear patterns            |



**45,000 MILE (72,000 KM) SERVICE**

| ITEM   |   | REMARKS   |
|--------|---|---|
| XU     | Air Filter                              | Replace   |
| D      | Crankcase Ventilation System            | Inspect; tighten, clean, adjust   |
|        | Damper, Cushion Drive                   | Visual inspection for cracks or deformation is required whenever the rear wheel is removed. Replace if damage is found. |
| D      | Drive Belt                              | Inspect; tighten, clean, adjust   |
| XU     | Engine Oil & Filter Change              | Change oil and filter, inspect used oil for contaminants  |
| E      | Evaporative Emission Control System     | Inspect; clean  |
| E      | Exhaust System                          | Inspect; tighten, adjust  |
| D      | Fuel System                             | Inspect; clean  |
| D      | Oil Lines / Oil System Inspection       | Inspect; clean, adjust if necessary   |
|        | Battery                                 | Check terminals; clean; test  |
| D      | Brake Fluid                             | Change every two years (DOT 4)  |
| XU / D | Brake Pads                              | Inspect pad wear; replace if worn beyond service limit  |
| D      | Clutch Lever                            | Lubricate with proper lubricant as directed   |
| D      | Clutch Cable Freeplay                   | Inspect; adjust if necessary  |
| D      | Control Cable Ends, Pinion Shaft Clevis | Inspect; lubricate with proper lubricant as directed  |
| D      | Fasteners                               | Inspect; tighten if necessary   |
| D      | Front Brake Lever                       | Lubricate with proper lubricant as directed   |
| D      | Front Fork Oil                          | Replace   |

## MAINTENANCE

| ITEM |                            | REMARKS   |
|------|----------------------------|---|
| D    | Front Forks and Front Axle | Inspect; adjust if necessary                          |
| D    | Gear Shift Pedal           | Inspect; adjust if necessary                          |
| D    | Rear Brake Pedal           | Inspect; adjust if necessary                          |
| D    | Rear Shock Absorber        | Inspect; adjust if necessary                          |
| D    | Rear Wheel Alignment       | Inspect; adjust if necessary                          |
|      | Road Test                  | Perform Road Test                                     |
| D    | Sidestand                  | Lubricate with proper lubricant as directed           |
| D    | Steering Bearings          | Inspect   |
| D    | Suspension Linkage, Rear   | Inspect   |
| D    | Swing Arm and Rear Axle    | Inspect   |
| D    | Tires / Wheels             | Inspect tread depth, sidewall cracking, wear patterns |

## 50,000 MILE (80,000 KM) SERVICE

| ITEM |                              | REMARKS   |
|------|------------------------------|---|
| XU   | Air Filter                   | Inspect; clean  |
| D    | Crankcase Ventilation System | Inspect; tighten, clean, adjust   |
|      | Damper, Cushion Drive        | Visual inspection for cracks or deformation is required whenever the rear wheel is removed. Replace if damage is found. |
| D    | Drive Belt                   | Inspect; tighten, clean, adjust   |
| D    | Engine Compression           | Inspect; correct if necessary   |

| ITEM   |   | REMARKS   |
|--------|---|---|
| D      | Engine Mount Fasteners                  | Inspect; tighten, adjust  |
| XU     | Engine Oil & Filter Change              | Change oil and filter, inspect used oil for contaminants  |
| E      | Evaporative Emission Control System     | Inspect; clean  |
| E      | Exhaust System                          | Inspect; tighten, adjust  |
| D      | Fuel Filter Replacement                 | Applies only to fuel pumps built before 11/10/2015.<br>Fuel pumps built after 11/11/2015 do not have a replaceable fuel filter. |
| D      | Fuel System                             | Inspect; clean  |
| D      | Oil Lines / Oil System Inspection       | Inspect; clean, adjust if necessary   |
| D / E  | Spark Plugs                             | Inspect; torque to specification  |
|        | Battery                                 | Check terminals; clean; test  |
| D      | Brake Fluid                             | Replace (DOT 4)   |
| XU / D | Brake Pads                              | Inspect pad wear; replace if worn beyond service limit  |
| D      | Clutch Lever                            | Lubricate with proper lubricant as directed   |
| D      | Clutch Cable Freeplay                   | Inspect; adjust if necessary  |
| D      | Control Cable Ends, Pinion Shaft Clevis | Lubricate with proper lubricant as directed   |
| D      | Fasteners                               | Inspect; tighten if necessary   |
| D      | Front Brake Lever                       | Adjust if necessary, lubricate with proper lubricant as directed  |
| D      | Front Fork Oil                          | Inspect   |
| D      | Front Forks and Front Axle              | Inspect; adjust if necessary  |
| D      | Gear Shift Pedal                        | Inspect; adjust if necessary  |

## MAINTENANCE

| ITEM |                          | REMARKS   |
|------|--------------------------|---|
| D    | Gear Position Switch     | Inspect; clean.                                       |
| D    | Head Light               | Inspect; adjust if necessary                          |
| D    | Rear Brake Pedal         | Inspect; adjust if necessary                          |
| D    | Rear Shock Absorber      | Replace   |
| D    | Rear Wheel Alignment     | Inspect; adjust if necessary                          |
|      | Road Test                | Perform Road Test                                     |
| D    | Sidestand                | Lubricate with proper lubricant as directed           |
| D    | Steering Bearings        | Inspect   |
| D    | Suspension Linkage, Rear | Inspect   |
| D    | Swing Arm and Rear Axle  | Inspect   |
| D    | Tires / Wheels           | Inspect tread depth, sidewall cracking, wear patterns |

When the vehicle goes beyond 50,000 miles, return to the 500 mile chart and start the interval process over.



## MAINTENANCE

### ENGINE OIL/FILTER CHANGE

Change the engine oil at the intervals specified in the Periodic Maintenance Table beginning on page 85. Change the oil more frequently if the motorcycle is subjected to severe use, especially operation in cold weather. See page 84.

#### NOTICE

Failure to perform frequent oil changes during cold weather operation can result in condensation forming. Freezing condensation can result in plugged oil lines and serious engine damage.

The total amount of oil required for the oil and filter change is approximately 6.0 qts. (5.7 l). Follow all instructions carefully. Do not overfill.

#### NOTICE

After an oil change, the low oil pressure indicator may illuminate when the engine is started. If this occurs, do not increase RPM above idle speed until the indicator turns off. Operating above idle speed could result in damage to the engine.

1. Change the oil and filter when the engine is warm. If the engine is cold, start the engine and allow it to run at idle for at least 5 minutes.
2. Park the motorcycle with the sidestand down on a firm, level surface. If using a service lift, the motorcycle should be centered.

3. Clean the area around the scavenge area drain plug ① and the storage area drain plug ②. Place a drain pan under both drain plugs.

#### CAUTION

Hot oil can cause burns to skin. Do not allow hot oil to contact skin.

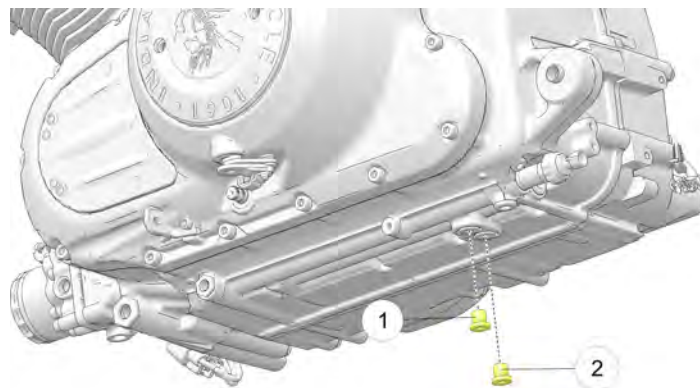

4. Remove the drain plugs. Allow the oil to drain completely.
5. Install new sealing washers on the drain plugs. The sealing surfaces on drain plugs and engine should be clean and free of burrs, nicks or scratches.

6. Reinstall the drain plugs. Torque to specifications.

**TORQUE**

Drain Plug: 15 ft. lbs. (20 Nm).

**⚠ CAUTION**

Hot oil can cause burns to skin. Do not allow hot oil to contact skin. Wear leather gloves when handling hot components.

7. Place oil pan beneath the oil filter. Using an oil filter wrench, turn the filter counter-clockwise to remove it.
8. Using a clean dry cloth, clean the filter sealing surface on the engine.
9. Lubricate the o-ring on the new filter with a film of fresh engine oil. Check to make sure the o-ring is in good condition.
10. Install the new filter and rotate it clockwise by hand until the filter gasket contacts the sealing surface, then turn it an additional 3/4 to one full turn.
11. Remove the dipstick. Add only 4.5 qts. (4.25 l) of the recommended oil at this step. *Do not overfill.*
12. Reinstall the dipstick securely.
13. With the motorcycle in an upright, centered position, start the engine and idle for 30 seconds.

14. Stop the engine and add the additional 1 – 1.5 qts. (0.95 – 1.42 l) of engine oil. Do not add oil if oil level is between the ADD and FULL marks. Overfilling can result in loss of engine performance and an oil-saturated air filter. Use suction device to remove excess oil if overfilled.
15. To ensure the oil level is within the safe operating range, re-check the oil level as outlined in page 63.

**NOTICE**

After an oil change, the low oil pressure indicator may illuminate when the engine is started. If this occurs, do not increase RPM above idle speed until the indicator turns off. Operating above idle speed could result in damage to the engine.

16. Dispose of used filter and oil properly.
17. Check for leaks around drain plug and oil filter.

**NOTICE**

Recycle used oil and oil filter in accordance with local regulations.

**FUEL FILTER**

The fuel filter is attached to the electric fuel pump located inside the fuel tank. See your authorized INDIAN MOTORCYCLE dealer or other qualified dealer for replacement.

## MAINTENANCE

### AIR FILTER

The air box is located on the left side of motorcycle. Inspect the air filter often if riding in unusually wet or dusty conditions. Replace the filter at the intervals specified in the Periodic Maintenance Table on page 85.

1. Remove the air box cover screws ①, and remove the cover ②.

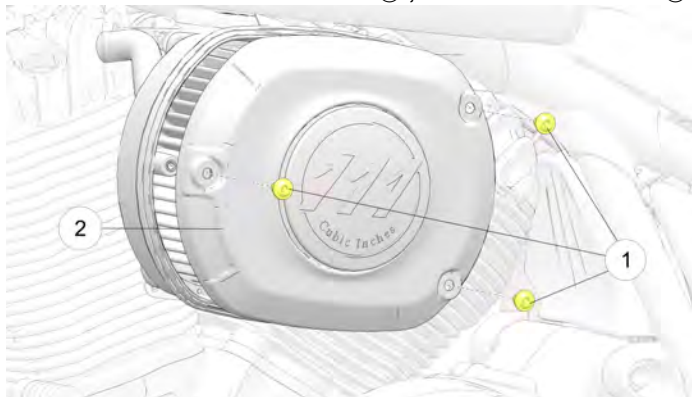

2. Remove the air filter ③ from the air filter housing.

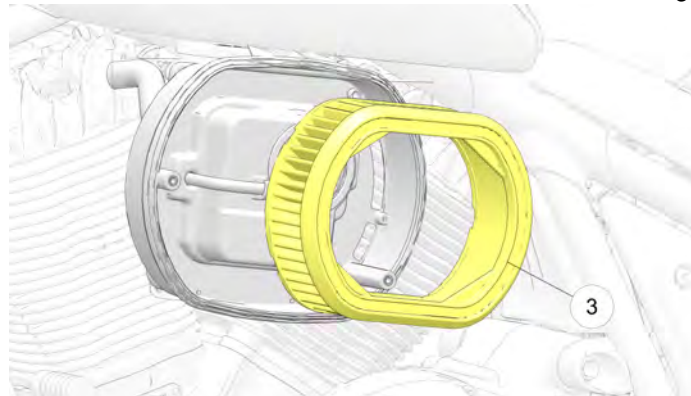

3. Clean the filter sealing surface on the backing plate.
4. Verify that the air box cover seal is properly seated in the airbox cover.
5. Position the air filter assembly against the air box backing plate.



- Reinstall the external air box cover and screws. Torque to specification.

| TORQUE             |
|--------------------|
| 7.4 ft-lbs (10 Nm) |

| NOTICE   |
|--|
| A loose fitting cover or improperly installed filter element may allow debris to enter the engine which may cause premature engine wear. |

## REAR DRIVE BELT CLEANING

| NOTICE  |
|---|
| Do not inspect or adjust drive belt tension when the belt or drive system is wet or hot. Improper adjustment will result. |

Cleaning the drive belt will maximize belt and sprocket life and minimize drive line noise. Clean the belt at every tire change. Clean the belt more often if riding in dirty, dusty or high debris environments.

- Mix a few drops of mild dish soap with a cup of warm water.
- Use a soft nylon brush to clean the belt and sprocket teeth with the soapy water. Clean well in corner areas where road debris and belt dust can collect.
- Rinse the belt with clear water, then dry thoroughly.

## REAR DRIVE BELT CONDITION

Inspect the rear drive belt at the intervals specified in the Periodic Maintenance Table on page 85. Replace the drive belt if it is cracked or has broken teeth. No matter its condition, the drive belt should be replaced at periodic intervals. See the *INDIAN MOTORCYCLE Service Manual* or an authorized *INDIAN MOTORCYCLE* dealer can assist.

DO NOT attempt to check belt tension if the belt has been exposed to rain or washing within a 24 hour period or if the vehicle has been run at operating temperature within the last four hours. Allow the vehicle to cool down to ambient temperature before measuring belt tension.

## REAR DRIVE BELT WEAR ANALYSIS

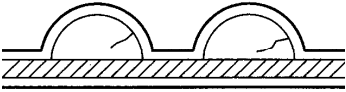
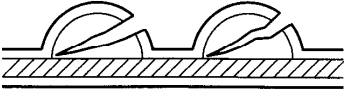
| WEAR ANALYSIS   | BELT CONDITION  |
|---|---|
| Internal tooth cracks (hairline):<br>OK to run, but monitor condition |  |
| External tooth cracks:<br>Replace belt                                |  |

# MAINTENANCE

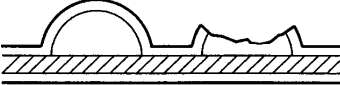
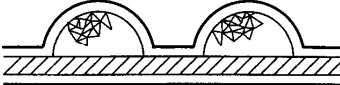
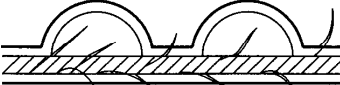
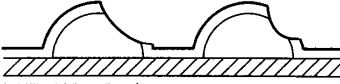
| WEAR ANALYSIS   | BELT CONDITION  |
|---|---|
| <p>Missing teeth:<br/>Replace belt</p>                              |  |
| <p>Chipping (not serious):<br/>OK to run, but monitor condition</p> |  |
| <p>Fuzzy edge cord:<br/>OK to run, but monitor condition</p>        |  |
| <p>Hook wear:<br/>Replace belt</p>                                  |  |

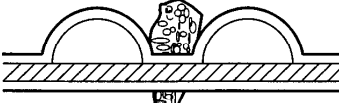
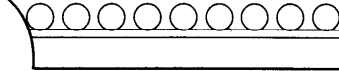
| WEAR ANALYSIS  | BELT CONDITION  |
|--|---|
| <p>Stone damage:<br/>Replace belt if damage is on edge</p>                   |  |
| <p>Bevel wear (outboard edge only):<br/>OK to run, but monitor condition</p> |  |

## DRIVE BELT ADJUSTMENT

### IMPORTANT

Drive belt adjustments should be performed by an authorized Indian dealer, or an equivalent technician.

### IMPORTANT

Perform this procedure to achieve proper belt tension *and* alignment. Belt tension should be set before performing the alignment procedure.

## BELT TENSION

### WARNING

A drive belt that is not properly tensioned can cause drive line noise and damage the drive belt, causing possible belt failure and loss of control of the motorcycle.

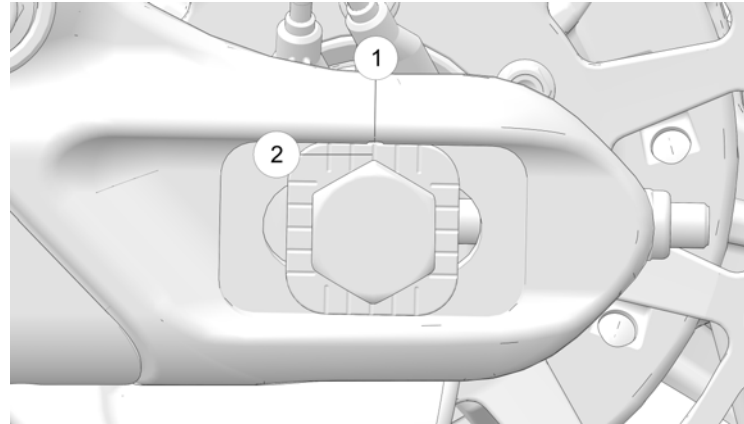

### NOTICE

Marks ① and ② are used as a reference for initial wheel alignment. Marks should be in roughly the same position on both left and right sides of wheel.

1. Place the motorcycle in an upright position with the front wheel clamped in a wheel vise.
2. Remove saddlebags if equipped.
3. Make note of adjuster locations ① and ②.

## MAINTENANCE

4. Raise the rear of the motorcycle so the rear tire can be freely rotated.
5. Loosen the axle bolt ③ and **retighten to the ADJUSTMENT SPECIFICATION during the adjustment procedure.**

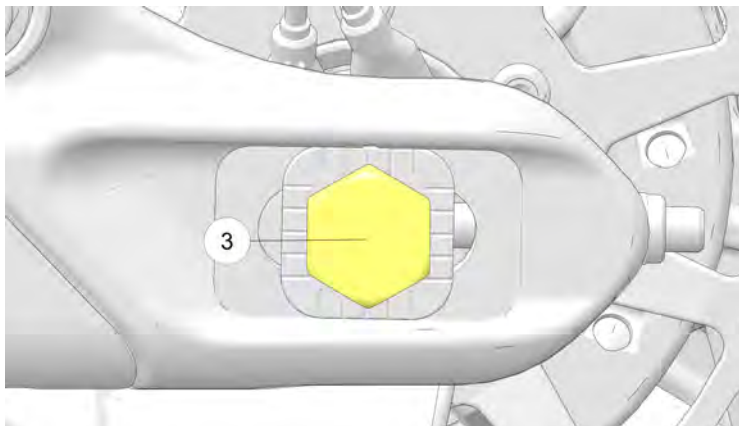

### TORQUE

Axle Bolt Torque (**ADJUSTMENT SPECIFICATION**): Initial Torque: 15 ft lbs (20 Nm)

6. Turn the RIGHT SIDE adjuster nut ④ to achieve proper belt tension.

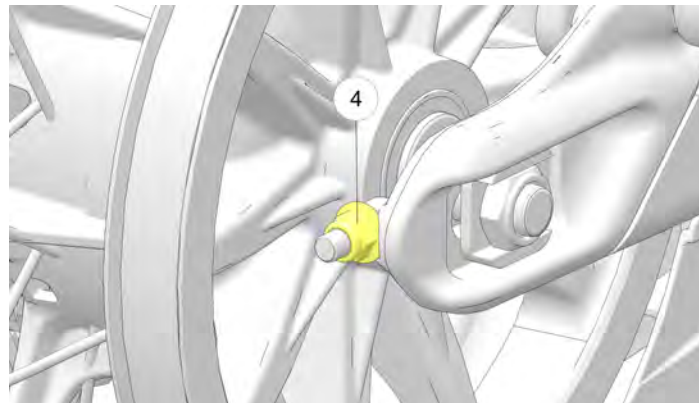

### BELT DEFLECTION

| Model                            | Deflection @ 10 lbs force |
|----------------------------------|---------------------------|
| Chief/ Chief Bobber/ Super Chief | 1.1" (28 mm)              |

## BELT ALIGNMENT

### WARNING

A drive belt that is not properly aligned can cause drive line noise and damage the drive belt, causing possible belt failure and loss of control of the motorcycle.

### NOTICE

To minimize change in belt tension, use LEFT SIDE adjuster only to make final adjustments to belt alignment.

1. Rotate the wheel BACKWARD. Tighten LEFT SIDE adjuster until belt comes off inside sprocket flange during backward wheel rotation.

### IMPORTANT

The belt should track to the center of the sprocket tooth surface when properly aligned ⑤. Sprocket teeth should be visible on both sides of the drive belt.

2. Rotate the wheel in the FORWARD direction and verify that sprocket teeth are still visible on both sides of the drive belt ⑤

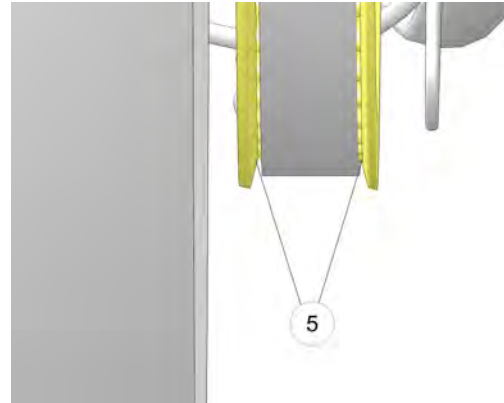

3. If necessary, loosen the axle bolt and LEFT SIDE adjuster until belt just moves off the right flange and begins to track down the center of the driven sprocket flange during forward wheel rotation.

### NOTICE

It may be necessary to loosen the axle bolt and tap the right end of the axle to ensure it moves forward when the adjuster is loosened. The axle bolt must be retightened to the ADJUSTMENT SPECIFICATION before proceeding.

4. Rear wheel alignment is satisfactory when the drive belt remains centered on driven sprocket during forward and backward wheel rotation. Sprocket teeth should be visible from both sides of the drive belt.

## MAINTENANCE

5. Verify that drive belt tension is still within specification.
6. Tighten rear axle bolt to FINAL specification.

### TORQUE

Axle Bolt Torque (**FINAL TIGHTENING**): Final Torque: 65 ft lbs  
(88 Nm)

7. Pump rear brake pedal several times to reset brake pad distance.
8. Verify wheel rotates smoothly and freely without drag when brake pedal is released.

## REAR SHOCK PRELOAD (RIDE HEIGHT) INSPECTION

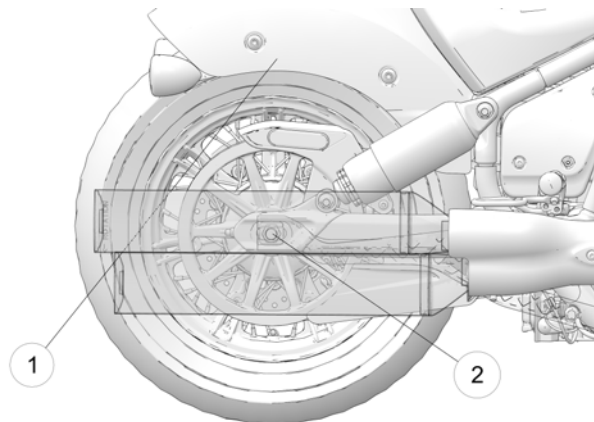

Periodically inspect rear shock preload. For the most comfortable ride and proper ground clearance, adjust preload if ride height is out of specification.

1. Verify that tire pressure is at specification. See page .
2. Secure the motorcycle in an upright position by clamping the front wheel in a wheel vise.
3. Remove the right-hand saddlebag (if equipped).
4. Apply a strip of tape ① to the rear fender directly over the center of the rear axle.

## SWING ARM/REAR AXLE INSPECTION

5. Using a suitable lift, raise the motorcycle until the rear shock is completely extended.
6. Measure the distance ② (*in millimeters*) from the center of the rear axle to the bottom of the tape. Record the results as measurement M1.
7. Lower the motorcycle and remove the lift.
8. Load the motorcycle with all intended cargo. Wearing your riding gear, bring the motorcycle to the upright position and sit on the operator's seat. If you plan to carry a passenger, have the passenger (with riding gear) sit on the passenger seat.
9. Have an assistant measure in the same location. Record the results as measurement M2.
10. Subtract measurement M2 from M1. The result is the measured rider sag. ( $M1-M2=Sag$ ). Adjust preload as needed.

1. Sit in the operator's seat and slowly bounce the rear suspension a few times. Make sure the suspension moves freely without binding. Listen for abnormal noises.
2. Elevate and support the motorcycle with the rear tire slightly off the floor. See page 157.



Make sure the motorcycle is stable when elevated. Injury may occur if the motorcycle tips or falls.

3. Grasp the rear wheel and attempt to move the wheel side-to-side. If there is movement at the front of the swingarm or in the axle area, see your dealer for service.
4. With the transmission in neutral, slowly rotate the rear wheel. If the wheel does not rotate smoothly, see your dealer for service.

| RECOMMENDED SUSPENSION SAG |      |                  |
|----------------------------|------|------------------|
| All Models                 | 45mm | 1.75 in. (1 3/4) |

### FRONT FORK/SUSPENSION INSPECTION

1. Place the motorcycle on the sidestand and inspect the front forks. If fork oil is present on the outer tube, *do not ride the motorcycle*. See your dealer for service before operating. If fork oil is present around the fork seals ① or inner tubes ②, replace the fork seals.

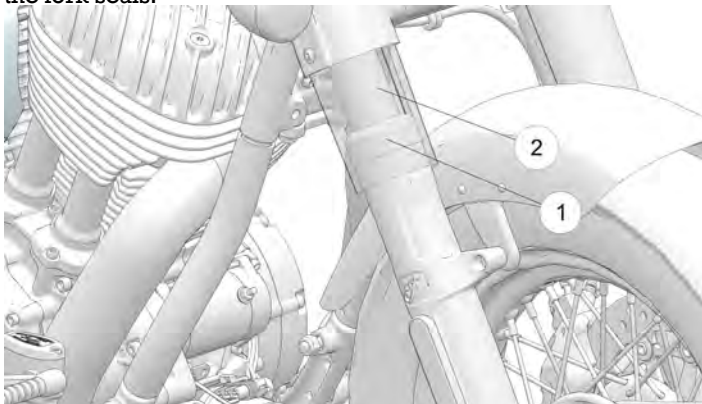

2. Clean the fork tubes to remove bugs, tar or buildup which may cause seal wear or leakage. Inspect the outer surfaces of the inner fork tubes for scratches or damage from foreign objects.

3. Straddle the motorcycle and bring it to the fully upright position. Apply the front brake and push downward (hard) on the handlebars several times. The front suspension should operate smoothly and quietly.
4. Fork oil condition and level affects front suspension performance and internal component wear. Replace fork oil at the recommended intervals. Special tools are required to perform this procedure. See the *INDIAN MOTORCYCLE Service Manual* or an authorized INDIAN MOTORCYCLE dealer can assist.

### STEERING HEAD INSPECTION

1. Elevate and support the motorcycle with the front tire slightly off the floor. See the Elevating the Motorcycle section for details.

#### CAUTION

Make sure the motorcycle is stable when elevated. Injury may occur if the motorcycle tips or falls.

2. Turn the handlebars from stop to stop. The action should be smooth but not loose. Make sure wires, hoses and control cables do not interfere with smooth steering.
3. Position the front wheel straight ahead. Grasp the front forks near the front axle and attempt to move the wheel front-to-back. If there is front-to-back movement at the steering head, see your dealer for service.



4. If steering binds, feels rough or uneven, or if movement is detected at the steering stem, see your dealer for service.
5. Rotate the front wheel and inspect for smooth rotation of front wheel bearings. If roughness or unusual sounds are present, see your dealer for service.
6. Turn handle bars full right or left and hold against the fork stop. Attempt to move front wheel side-to-side. If movement is observed, see your dealer for service.

## CRANKCASE BREATHER HOSES

Inspect both breather hoses along their length and at both ends. Make sure hoses are not restricted, kinked, cracked or otherwise damaged. Replace any worn or damaged hoses.

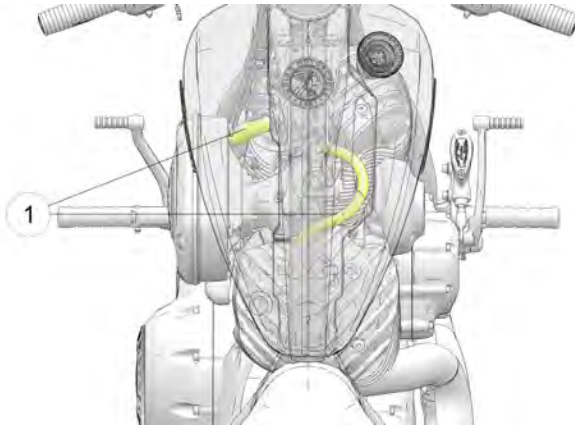

## EVAPORATIVE EMISSION CONTROL SYSTEM (CALIFORNIA AND INTERNATIONAL MODELS)

1. Inspect all evaporative emission control system hoses and connections. Make sure all connections are fully seated.
2. The canister ① is located under the rider's seat, behind the left frame cover. Make sure it is fully seated on the mounting bracket.
3. Inspect connections at the evaporative emissions canister to ensure they are secure. The vent line coming from the tank should be connected to the port labeled "TANK." The purge line should be connected to port labeled "PURGE."

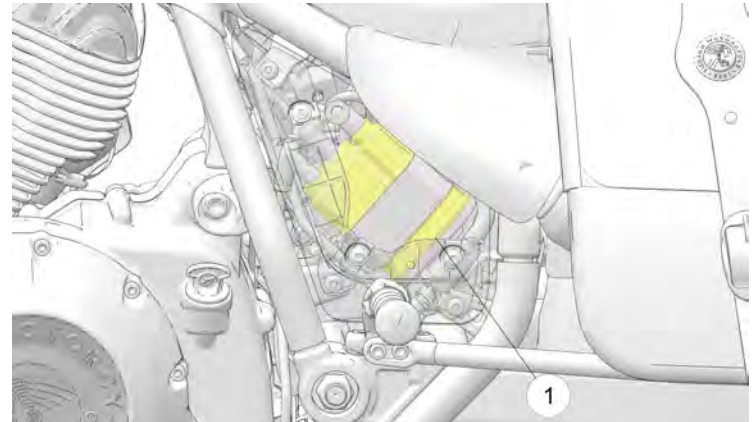

## MAINTENANCE

### FUEL SYSTEM COMPONENTS

1. Inspect fuel hoses for cracks or damage.
2. Inspect hose connections at the fuel tank ① and at the fuel rail for dampness or stains from leaks. The tank connection for the fuel line is under the tank console.
3. The fuel system is under pressure and caution must be used when inspecting and servicing the fuel system. See the *INDIAN MOTORCYCLE Service Manual* or an authorized INDIAN MOTORCYCLE dealer can assist.

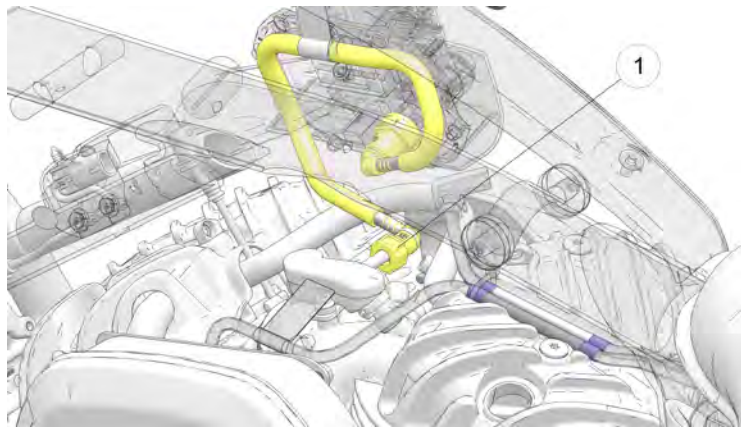

### THROTTLE CONTROL INSPECTION

1. With the engine OFF, rotate the throttle control grip fully open and then release it. It should rotate smoothly from the rest position to the completely open position. It should return to the rest position quickly when released.
2. Service the throttle system if throttle operation is not smooth or if throttle grip does not return properly. See the *INDIAN MOTORCYCLE Service Manual* or an authorized INDIAN MOTORCYCLE dealer can assist.

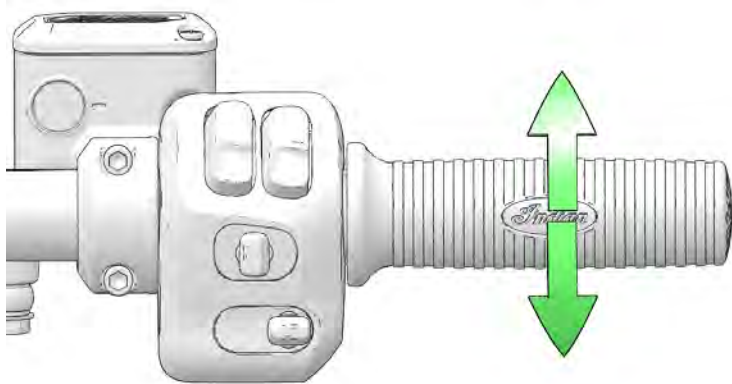

### SIDESTAND LUBRICATION

Periodically lubricate the sidestand bushing. See page 40 for sidestand inspections.

## MECHANICAL CLUTCH LEVER FREEPLAY

1. Position the handlebars in the straight-ahead position before measuring clutch lever freeplay.
2. The clutch cable adjuster nut is located on the bottom of the clutch cover on the engine. Loosen the lock nut.
3. Turn the cable adjuster inward or outward until clutch lever freeplay is 0.5-1.5 mm as measured at the clutch perch.
4. While holding the cable, tighten the adjuster lock nut securely.
5. Verify that the safety switch activates properly. The engine should not start in gear with the clutch lever released. Never test the clutch safety switch by attempting to start the motorcycle in gear unless the rear wheel is raised off the ground.

### TIP

The starter interlock switch is dependent on the clutch lever freeplay being set correctly to ensure activation of the clutch safety switch.

## MECHANICAL CLUTCH LEVER LUBRICATION

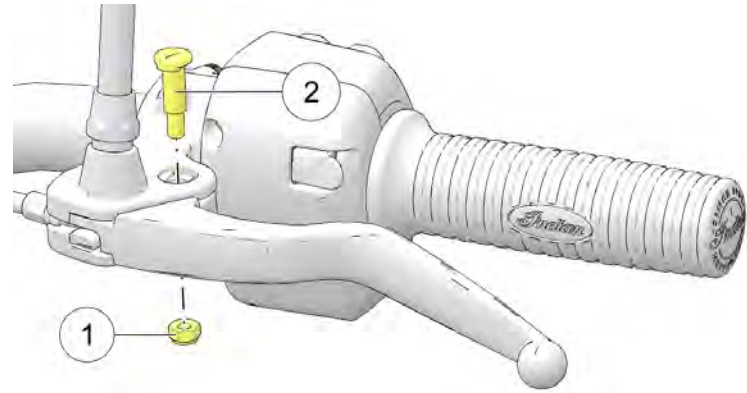

1. The clutch cable adjuster nut is located on the bottom of the clutch cover on the engine. Loosen the lock nut.
2. Turn the cable adjuster completely inward to provide maximum lever freeplay.
3. Remove the nut ① and pivot pin ②. Disconnect the clutch cable from the clutch lever.

## MAINTENANCE

---

4. Remove any old grease and dirt from the lever and housing. Lubricate the clutch lever and pin with moly assembly grease or all-purpose grease.

### NOTICE

During installation of the lever, be aware of the internal clutch switch. Improper assembly can cause damage to the switch.

5. Reconnect the clutch cable. Reinstall the pivot pin and nut.
6. Adjust clutch lever freeplay. See page 121.
7. Tighten the adjuster nut.

## MECHANICAL CLUTCH CABLE LUBRICATION

Lubricate control cable ends at the intervals recommended in the Periodic Maintenance Table beginning on page 85.

### NOTICE

External casings are factory-lubricated. Additional lubrication could be detrimental to cable performance.

Verify proper routing and smooth movement. Inspect for damage to the external casing, and inspect exposed cable wire for fraying, kinks or corrosion. Replace any damaged, sticky or sluggish cable.

1. Disconnect the cable at the clutch lever and at the primary cover.
2. Lubricate the barrel ends with all-purpose grease.

3. Lubricate the clutch clevis/pinion pivot.
4. Reconnect the cable and adjust freeplay as needed.

## BRAKE HOSES/CONNECTIONS

Inspect all brake hoses and connections for dampness or stains from leaking or dried fluid. Tighten any leaking connections and replace components as necessary. See the *INDIAN MOTORCYCLE Service Manual* or an authorized INDIAN MOTORCYCLE dealer can assist.

## REAR BRAKE PEDAL

1. Lubricate the pivot bushing at the intervals recommended in the Periodic Maintenance Table beginning on page 85. Also lubricate any time binding is evident. Use all-purpose grease.
2. Inspect brake pads as outlined in the Brake Pads section.

## BRAKE FLUID PRECAUTIONS

### WARNING

Using the wrong fluid or allowing air or contaminants into the fluid system can damage the system seals or result in a malfunction that could lead to serious injury or death. Use only DOT 4 brake fluid from a sealed container.

Do not operate the front brake with the reservoir cover removed. Fluid could overflow from the reservoir and allow air to enter the system. Air in the brake system could cause the brakes to malfunction.

An over-full reservoir may cause brake drag or brake lock-up, which could result in serious injury or death. Maintain brake fluid at the recommended level. Do not overfill.

### NOTICE

Brake fluid will damage painted surfaces and plastic parts. Always clean spilled brake fluid immediately with water and a mild detergent.

## REAR BRAKE FLUID

Change the brake fluid at the intervals recommended in the Periodic Maintenance Chart on page 84. Always add brake fluid from a new, unopened container. Always use the recommended fluid. See page 175.

1. Position the motorcycle on level ground in the fully upright position.
2. The rear brake fluid reservoir is located near the rear brake pedal. View the reservoir from the right side of the vehicle.
3. Wipe the fluid container and the area around the reservoir cover with a clean cloth.
4. If the fluid level is low, inspect brake pads as outlined on page 126. If pads are not worn beyond the service limit, inspect the brake system for leaks.

## MAINTENANCE

5. Remove the cover and diaphragm. The fluid level should be above the minimum indicator mark ② on the reservoir body ①. Add brake fluid as needed. *Do not overfill.*

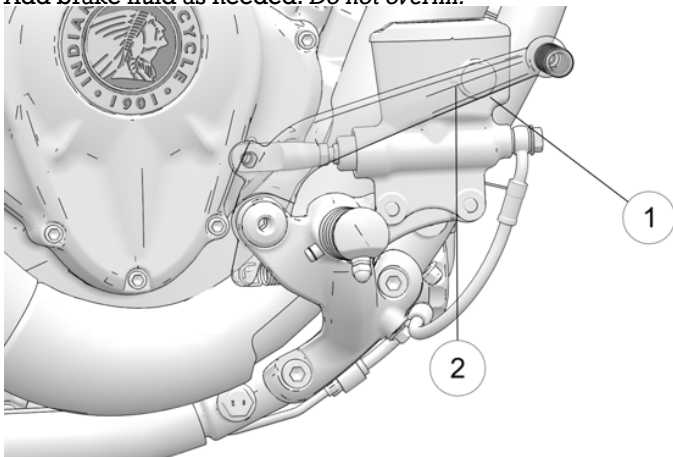

6. Reinstall the cover and diaphragm.
7. Wipe away any fluid spills. Check for signs of brake fluid leaks around hoses, fittings, reservoir, and brake calipers.

## FRONT BRAKE LEVER

1. Lubricate the pivot pin ① and brake lever hinge points at the intervals recommended in the Periodic Maintenance Table. Also lubricate any time binding is evident. Use all-purpose grease.

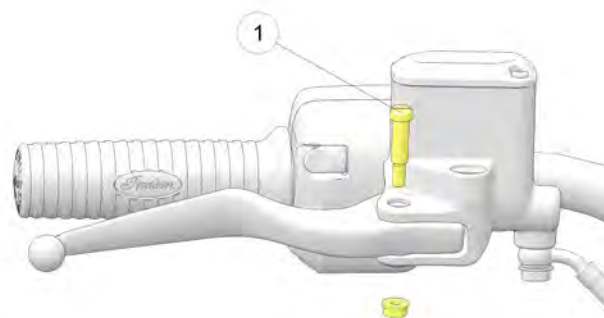

2. Install the pivot pin ①. Torque the pivot pin to specifications.

### TORQUE

Pivot Pin: 9 in lbs (1 Nm)

3. Install the pivot pin nut ② onto the pivot pin ①. Torque the pivot pin nut to specifications.

**TORQUE**

Pivot Pin Nut: 52 in lbs (5.9 Nm)

4. Inspect brake pads as outlined on page 126.

**FRONT BRAKE FLUID**

Change the brake fluid at the intervals recommended in the Periodic Maintenance Table. Do not attempt to change the brake fluid in a model equipped with an anti-lock brake system. Please see your dealer for this service. Always add brake fluid from a new, unopened container. Always use the recommended fluid. See page 175.

1. Position the motorcycle on level ground in the fully upright position. Position the handlebars so that the fluid reservoir is level. Wipe the fluid container and the area around the reservoir cover with a clean cloth.
2. If the fluid level is low, inspect brake pads as outlined on page 126. If pads are not worn beyond the service limit, inspect the brake system for leaks.
3. To add fluid, remove the reservoir cover screws. Remove the cover and diaphragm.

4. The fluid level should be above the minimum indicator mark ① in the sight glass ②. Add brake fluid as needed. *Do not overfill.*



5. Reinstall the diaphragm, cover and screws.

**TORQUE**

13 in-lbs (1.4 Nm)

6. Wipe away any fluid spills. Check for signs of brake fluid leaks around hoses, fittings, reservoir and brake calipers. Check for deterioration of hoses.

## MAINTENANCE

### BRAKE DISC INSPECTION/CLEANING

1. Inspect brake discs ① for nicks, scratches, cracks or other damage. Inspect the thickness of each brake disc at four or more locations around the disc. If any disc is worn to the minimum thickness at the thinnest point, or if a disc is damaged, see your dealer for replacement.



Parts may be hot. Allow adequate time for the brake discs and other components to cool before inspecting.

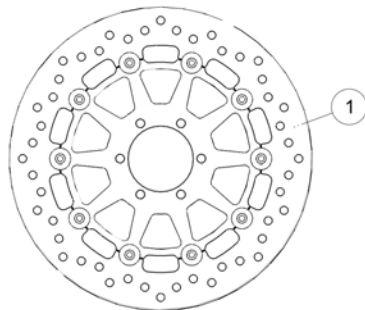

#### NOTICE

**Minimum Thickness:** Front: 4.5mm; Rear 4.5mm

2. Clean discs if minor squeaks develop due to dirt or dust. Apply brake cleaner to a clean shop towel and wipe the discs. DO NOT allow brake cleaner to contact painted or plastic parts. Read all precautions on the label.

### BRAKE PADS

Inspect each front brake pad on both sides of the front disc. Inspect each rear brake pad on both sides of the rear disc. Replace brake pads when the thinnest point of the friction material ② has worn to 1.0 mm. Please see your dealer for this service.

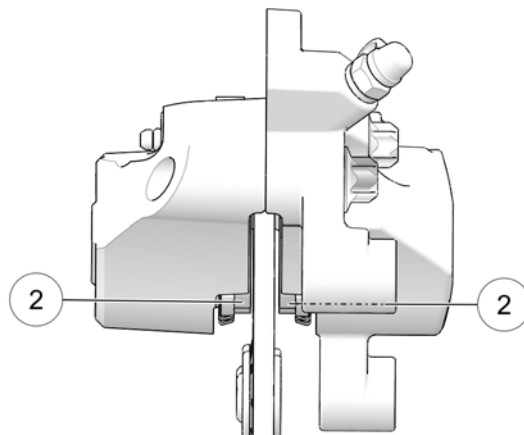



**NOTICE**

After replacing pads, allow up to 250 miles (500 km) of operation in urban driving conditions (not highway cruising) to allow pads to mate with new rotors. Brakes should be used frequently. During this time brake performance will be less effective. Avoid using brakes harshly unless in an emergency. Brake efficiency will gradually increase during this seating period.

When checking brake pad friction material thickness, check each brake caliper for dampness or stains from leaking or dried brake fluid. If inspection reveals signs of fluid leakage, do not operate the vehicle. See your dealer for service.

**FRONT BRAKE PAD INSPECTION**

1. Position the motorcycle on the sidestand with the handlebars turned to the left.
2. Use an inspection mirror, positioned at the front side of the brake caliper, to view the friction material.

**REAR BRAKE PAD INSPECTION**

1. Position the motorcycle on the sidestand with the handlebars turned to the left.
2. Use an inspection mirror, positioned at the front side of the caliper, to view the friction material.

**WHEEL SPOKES (IF EQUIPPED)**

Inspect both wheels for loose, bent, broken or missing spokes (if equipped). To identify loose spokes, grasp each spoke and try to move it side to side or up and down. All spokes should be equally tight and have the same amount of flex. Tighten loose spokes and replace bent, broken or missing spokes (see an authorized dealer).



**WARNING**

Spokes adjusted or replaced improperly could distort the wheel, make the motorcycle difficult to handle, and cause loss of control.

**WHEEL INSPECTION**

Inspect both wheels for cracks or damage and replace damaged wheels promptly. Do not operate the motorcycle if wheels are damaged or cracked. See the *INDIAN MOTORCYCLE Service Manual* or an authorized INDIAN MOTORCYCLE dealer can assist.

**WHEEL ALIGNMENT**

Inspect rear wheel alignment at regular service intervals, whenever the rear wheel is removed and when the rear drive belt is adjusted. Please see your dealer for this service.

## MAINTENANCE

### FRONT WHEEL INSTALLATION

If the front wheel is removed for any reason, it must be reinstalled in the correct rotating direction.

Clean all wheel components before installation. Apply a light coat of all-purpose grease to the axle and both spacers.

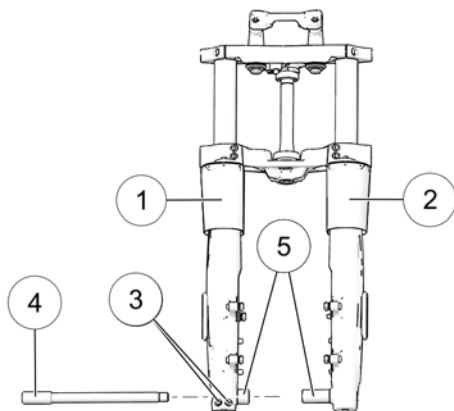

- ① Right Fork Tube
- ② Left Fork Tube
- ③ Pinch Bolt 18–19 ft-lbs. (24.4–25.7 Nm)
- ④ Axle Bolt 52 ft-lbs. (70 Nm)
- ⑤ Wheel Spacers 0.925 in. (23.5 mm)

### TIRES

#### WARNING

Operating the motorcycle with incorrect tires, incorrect tire pressure or excessively worn tires could cause loss of control or accident. Under-inflation can cause a tire to overheat and result in a tire failure. Always use the correct size and type of tires specified by INDIAN MOTORCYCLE for your vehicle. Only use tires approved by Indian Motorcycle for the model of motorcycle. See your dealer. Use of unapproved or an improperly matched front and rear tire can result in decreased handling performance and stability, potentially leading to reduced control of the motorcycle.

### TIRE REPLACEMENT

#### NOTICE

On models equipped with a TPMS, the sensors are located 180° from the valve stem. Use caution when servicing tires. To avoid damaging a sensor, break the bead at the valve stem, then at 90° and 270° from the valve stem as required.

Tires, rims, innertubes and air valves must be correctly matched to wheel rims. Use only the proper size tires specified with the same or higher load ratings. INDIAN MOTORCYCLE-recommended tires provide proper clearance between fenders, swingarm, drive belts and other components. See the Specifications chapter.

On models equipped with innertubes, innertubes **MUST** be replaced with new innertubes when tires are replaced. Use only the proper size innertubes.

 **WARNING**

Mismatched tires, rims and air valves may result in damage to the tire bead during mounting or may allow the tire to slip off the rim, possibly resulting in tire failure.

## **TIRE CONDITION**

Inspect the tire sidewalls, road contact surface, and tread base for cuts, punctures, and cracking. Replace damaged tires immediately. See the *INDIAN MOTORCYCLE Service Manual* or an authorized INDIAN MOTORCYCLE dealer can assist.

## **TIRE TREAD DEPTH**

Replace any tire with a tread depth of less than 1/16 inch (1.6 mm).

Tread wear indicators are located in at least six places on the tread circumference and become visible at a tread depth of approximately 1/16 inch (1.6 mm). The tread wear indicators appear as a solid band across the tread.

You may also use a depth gauge or an accurate ruler to measure the depth of the center tire tread on both front and rear tires.

## MAINTENANCE

### TIRE PRESSURE

Always check and adjust tire pressure when tires are cold. Do not adjust tire pressure immediately after riding. Wait at least 3 hours after riding to check pressure. If pressure is checked and adjusted while tires are warm, the pressure will drop as tires cool and result in under inflation. Adjust tire pressure as recommended for the total weight of your intended load (see tire pressure chart). For

more information, refer to the manufacturing information label located on the front frame down tube.



Do not exceed the maximum recommended inflation pressure to seat the bead. Tire or rim failure may result.

### TIRE PRESSURE CHART

| LOCATION                       | SIZE           | BRAND    | TYPE         | RECOMMENDED PRESSURE            |   |
|--------------------------------|----------------|----------|--------------|---------------------------------|---|
|                                |                |          |              | LOADS UP TO 200 LBS.<br>(91 KG) | LOADS UP TO<br>VEHICLE'S MAXIMUM<br>LOAD CAPACITY |
| <b>CHIEF</b>                   |                |          |              |                                 |   |
| Front                          | 130/60 B19 61H | Pirelli® | Night Dragon | 36 psi (248 kPa)                | 36 psi (248 kPa)                                  |
| Rear                           | 180/65 B16 81H | Pirelli® | Night Dragon | 40 psi (276 kPa)                | 40 psi (276 kPa)                                  |
| <b>CHIEF DARK HORSE</b>        |                |          |              |                                 |   |
| Front                          | 130/60 B19 61H | Pirelli® | Night Dragon | 36 psi (248 kPa)                | 36 psi (248 kPa)                                  |
| Rear                           | 180/65 B16 81H | Pirelli® | Night Dragon | 40 psi (276 kPa)                | 40 psi (276 kPa)                                  |
| <b>CHIEF BOBBER</b>            |                |          |              |                                 |   |
| Front                          | 130/90 B16 67H | Pirelli® | Night Dragon | 36 psi (248 kPa)                | 36 psi (248 kPa)                                  |
| Rear                           | 180/65 B16 81H | Pirelli® | Night Dragon | 40 psi (276 kPa)                | 40 psi (276 kPa)                                  |
| <b>CHIEF BOBBER DARK HORSE</b> |                |          |              |                                 |   |
| Front                          | 130/90 B16 67H | Pirelli® | Night Dragon | 36 psi (248 kPa)                | 36 psi (248 kPa)                                  |

MAINTENANCE

| LOCATION                   | SIZE           | BRAND    | TYPE         | RECOMMENDED PRESSURE            |   |
|----------------------------|----------------|----------|--------------|---------------------------------|---|
|                            |                |          |              | LOADS UP TO 200 LBS.<br>(91 KG) | LOADS UP TO<br>VEHICLE'S MAXIMUM<br>LOAD CAPACITY |
| Rear                       | 180/65 B16 81H | Pirelli® | Night Dragon | 40 psi (276 kPa)                | 40 psi (276 kPa)                                  |
| <b>SUPER CHIEF</b>         |                |          |              |                                 |   |
| Front                      | 130/90 B16 67H | Pirelli® | Night Dragon | 36 psi (248 kPa)                | 36 psi (248 kPa)                                  |
| Rear                       | 180/65 B16 81H | Pirelli® | Night Dragon | 40 psi (276 kPa)                | 40 psi (276 kPa)                                  |
| <b>SUPER CHIEF LIMITED</b> |                |          |              |                                 |   |
| Front                      | 130/90 B16 67H | Pirelli® | Night Dragon | 36 psi (248 kPa)                | 36 psi (248 kPa)                                  |
| Rear                       | 180/65 B16 81H | Pirelli® | Night Dragon | 40 psi (276 kPa)                | 40 psi (276 kPa)                                  |

## MAINTENANCE

### HANDLEBAR POSITION

On models equipped with two handlebar positions, the motorcycle is manufactured with handlebars in the low position. Before changing handlebar position, check regulations in your area of operation. Operation with the handlebars in the high position may not be legal in all areas for all riders.

#### WARNING

Handlebar control position must be checked for proper alignment each time handlebar position is changed. Failure to reposition controls could result in loss of vehicle control resulting in serious injury or death.

To change the handlebar position, do the following:

#### CAUTION

Protect painted surfaces on the front fender and fuel tank prior to beginning the following procedure. Use care when removing the nacelle so the chrome and paint do not get scratched.

#### CAUTION

During disassembly, pay close attention to harness routing and connector orientation. Always route electrical wiring the same way as it was removed to avoid damaging wires and connectors.

1. Remove windshield assembly, if equipped.
2. Loosen all four handlebar clamp fasteners ①. There are two additional handlebar clamp fasteners located under the handlebar clamp.

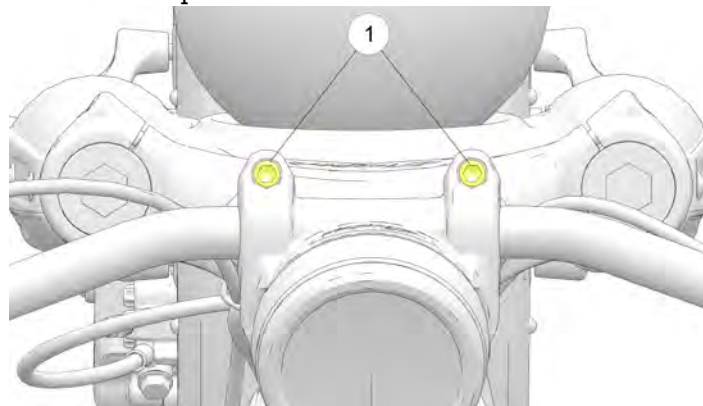

3. Rotate the handlebar into the desired position and torque the riser clamp fasteners to specification.

#### TORQUE

Riser Clamp Fasteners: 18ft-lbs (25 Nm) Tighten front fasteners first, then rear.

4. Install windshield assembly, if equipped.
5. Verify that all controls are operating correctly and the handlebar turns freely from lock to lock.

## SPARK PLUGS

Inspect spark plugs ① after the break-in period and every 20,000 miles (32,000 km) thereafter. Replace spark plugs every 40,000 miles (64,000 km). Always replace spark plugs in pairs.

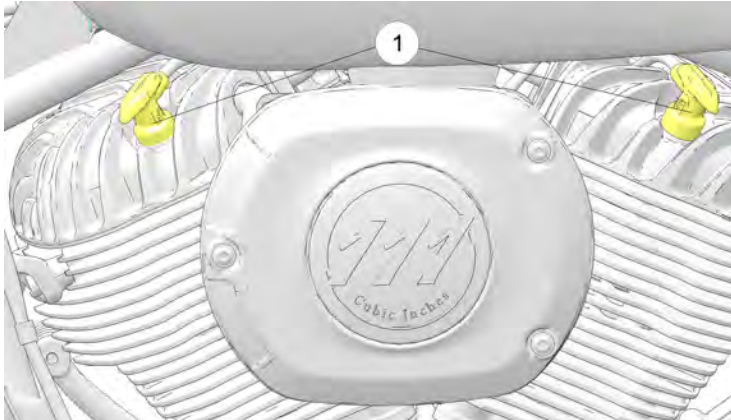

| SPARK PLUG SPECIFICATIONS |                     |
|---------------------------|---------------------|
| Spark Plug Type           | NGK® DCPR8E         |
| Spark Plug Gap            | .034 inch (.9 mm)   |
| Spark Plug Torque         | 12 ft-lbs (16.3 Nm) |

1. Make sure the engine has cooled to room temperature.
2. Turn the power switch off.
3. Pull upward on the spark plug boots (not the wires) to remove the boots.
4. To prevent debris from entering the spark plug holes, use compressed air to clean the area around the plugs before removing them.

**Tool:** 12 mm plug socket

### ⚠ CAUTION

Wear eye and face protection when using pressurized air.

5. Reinstall the spark plugs or install new plugs.

### TORQUE

Spark Plug: 12.7 ft-lbs (17.2 Nm)

6. Reinstall the spark plug boots.

## MAINTENANCE

### SEAT REMOVAL

To remove the seat, do the following:

1. Place the motorcycle on a level surface, with the kickstand extended.
2. Locate the seat removal tool ① attached to the motorcycle undertray.

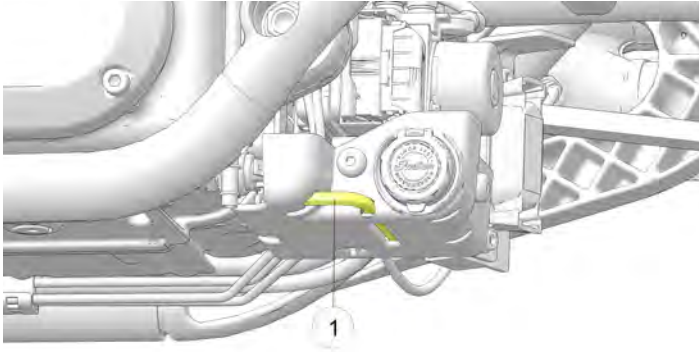

3. On models equipped with a passenger seat, remove the rear seat bracket bolt ②, washer, and nylon grommet.

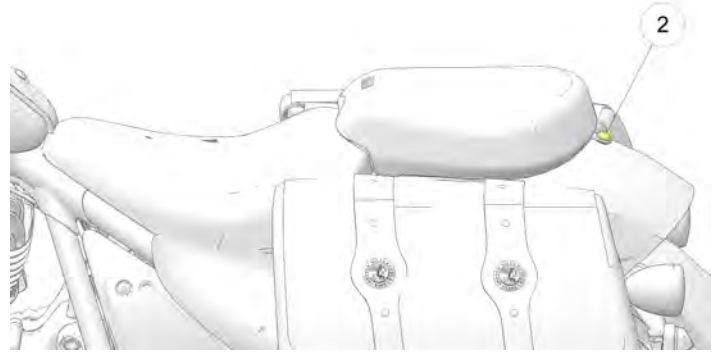



4. Lift the rear of the seat and pull upwards to disengage the seat grommet from the passenger seat post. Continue to pull up on the seat until the grab strap is pulled completely through the seat.
5. Remove the passenger seat post from the front seat bracket ③. Lift the rear of the seat and pull rearward to disengage the front seat from the front frame mount.

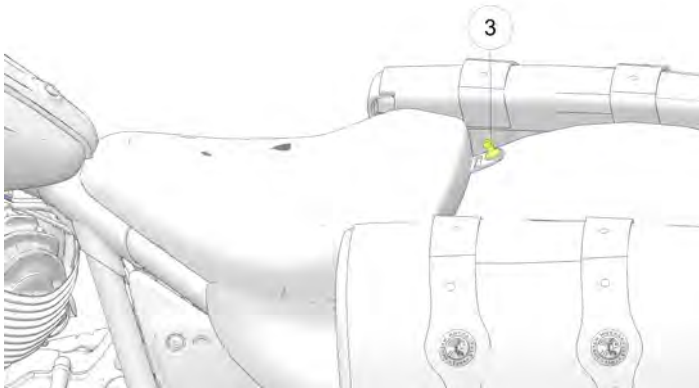

## SEAT INSTALLATION

1. Position the seat by inserting the seat mounting tabs from rear to front into the frame.
2. Rotate the rear of the seat downward and position the rear mount seat bracket onto the fender.

3. Thread the seat mount bolt through the seat mount bracket and into the fender. Torque the seat bolt to specification.

| TORQUE            |
|-------------------|
| 13 ft-lbs (18 Nm) |

4. Position the passenger seat near the fender, and push the grab strap through the seat bottom (if equipped).
5. Lower the passenger seat onto the seat post, and push downward to engage the seat grommet to the seat post.
6. Gently raise the rear bracket and reinstall the nylon grommet.
7. Thread the rear bracket bolt and washer through the bracket and nylon grommet. Torque the bolt to specification.

| TORQUE            |
|-------------------|
| 13 ft-lbs (18 Nm) |

## LIGHTS

### HEADLIGHT AIM INSPECTION

Adjust headlight aim when there is a change in load (rider, cargo, accessories, etc.) or after suspension adjustment.

## MAINTENANCE

### MODELS EQUIPPED WITH LED HEADLIGHTS

With the headlight switched to LOW beam, the top of the highest intensity (appears as a diamond shape) should be 4.0 in (10 cm) below the height of the headlight bulb ③ when centered straight ahead at 32 feet 10 inches (10 m).

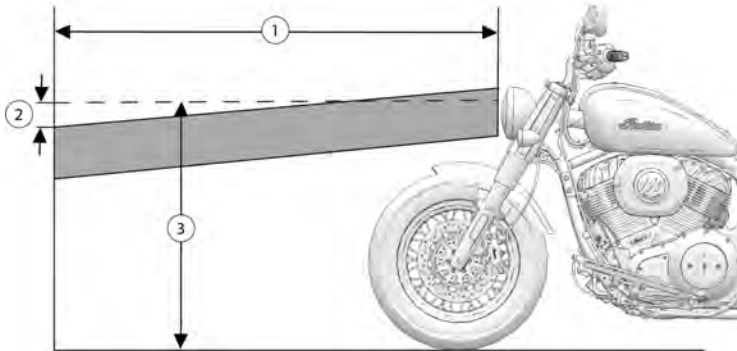

| LOCATION | MEASUREMENT          |
|----------|----------------------|
| ①        | 32 ft. 10 in. (10 m) |
| ②        | 4.0 in. (10 cm)      |
| ③        | Center of low beam   |

### HEADLIGHT INSPECTION PROCEDURE

Follow all steps below to ensure accurate aim inspection.

1. Check and adjust the tire pressure to specification.
2. Verify suspension ride height (preload) is set to specification.
3. Move the motorcycle to a clear area with a level floor and dim lighting, and place it so the top front edge of the headlight housing is 32 ft. 10 in. (10 m) from the wall.
4. With the rider and passenger (if applicable) on board, bring the motorcycle to a fully upright position. Center the handlebars in a straight ahead position.
5. Start the engine and switch the headlight on to the low setting.
6. Compare the position of headlight beam on the wall to the illustration. Adjust if necessary.

### HEADLIGHT AIM ADJUSTMENT

The headlamp adjustment screw ① is located on the left side of the headlamp housing base.

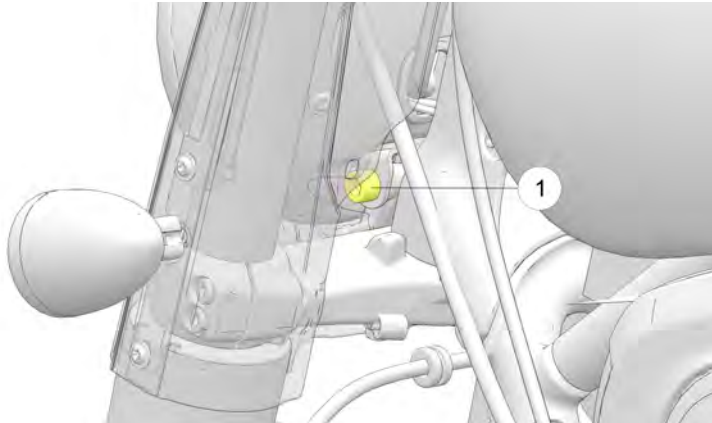

1. To adjust the headlight vertically, loosen the headlamp pivot fastener. Rotate the headlight assembly upward or downward.
2. When the headlight beam is correct, tighten the fastener to specification.

**TORQUE**

29 ft-lbs (40 Nm)

**HEADLIGHT LAMP REPLACEMENT**

The LED headlight is not serviceable. If the headlight becomes damaged or inoperable, the entire headlight assembly must be replaced. See your authorized INDIAN MOTORCYCLE dealer.

**LED TAILLIGHT/BRAKE LIGHT REPLACEMENT**

The LED taillight and brake lights are not serviceable. If the taillight or a brake light becomes damaged or inoperable, the entire light assembly must be replaced. See your authorized INDIAN MOTORCYCLE dealer or other authorized dealer.

**BATTERY**

The motorcycle battery is a sealed, maintenance-free battery. Do not remove the battery cap strip for any reason. Keep the battery connections clean and tight at all times.

**⚠ WARNING**

Battery electrolyte is poisonous. It contains sulfuric acid. Serious burns can result from contact with skin, eyes or clothing.

**Antidote:**

**External:** Flush with water.

**Internal:** Drink large quantities of water or milk. Follow with milk of magnesia, beaten egg, or vegetable oil. Call physician immediately.

**Eyes:** Flush with water for 15 minutes and get prompt medical attention.

Batteries may produce explosive gases.

## MAINTENANCE

- Keep sparks, flame, cigarettes, etc. away.
- Ventilate when charging or using in an enclosed space.
- Always shield eyes when working near batteries.
- KEEP OUT OF REACH OF CHILDREN.

### KEY FOB BATTERY LIFE:

Key fob battery life is approximately 1-2 years depending on fob type and usage patterns. Battery changes recommended yearly. Multi-Function (Two Button) Key Fob battery life will decrease with frequent use of the LOCK / UNLOCK buttons.

#### Low Battery Indicators:

- Decreased fob authentication range
- Horn honks 5 seconds after startup
- Security light stays illuminated for up to 20 seconds
- Both Battery Light and Security Light are illuminated

#### Key Fob performance can be affected by the following conditions:

- Close proximity of ferrous materials (e.g. money clip or pocket knife)
- Key Fob stuck to saddlebag speaker magnet
- Key Fob held in ferrous container (metal cup holder or glasses case)
- Cold temperatures (Key Fob should be kept above 45°F / 7°C)

Key Fob Replacement Battery Part Number: 4014675 or CR2032

## BATTERY REMOVAL



Improperly connecting or disconnecting battery cables can result in an explosion and cause serious injury or death. When removing the battery, always disconnect the negative (black) cable first. When reinstalling the battery, always connect the negative (black) cable last.

1. Remove the seat. See page 134.
2. Remove the Wireless Control Module (WCM) ① by disconnecting its electrical connector ② and removing it from the upper battery tray.

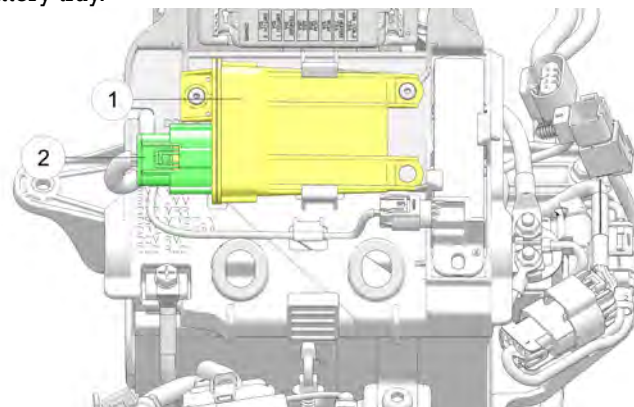

3. Remove the antenna ③ by disconnecting its electrical connector ④ and removing it from the upper battery tray.

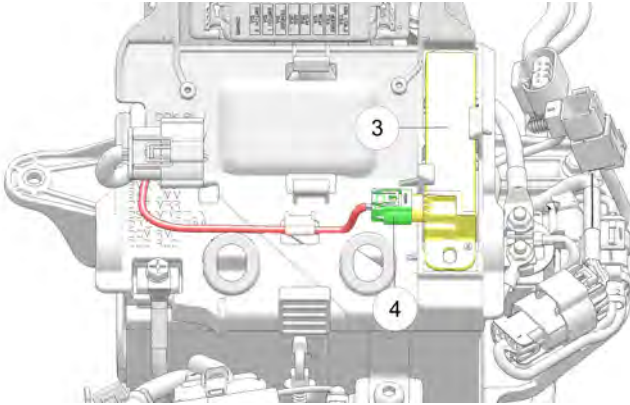

4. Disconnect the wiring harness from the upper battery tray by removing it from the two retention areas and move it off to the left side of the bike.

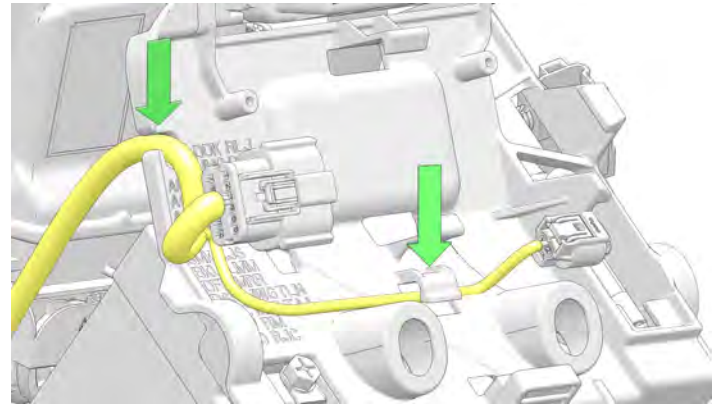

## MAINTENANCE

---

5. Remove the negative (-) battery cable ⑤ from the battery terminal. Position the cable well clear of the terminal.

**Tool:** 10 mm wrench

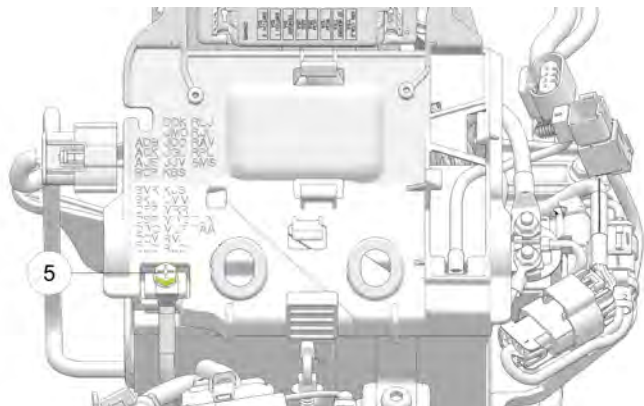

6. Remove the rubber strap ⑥ from the battery cover by pulling up on the strap, then to the rear of the bike.

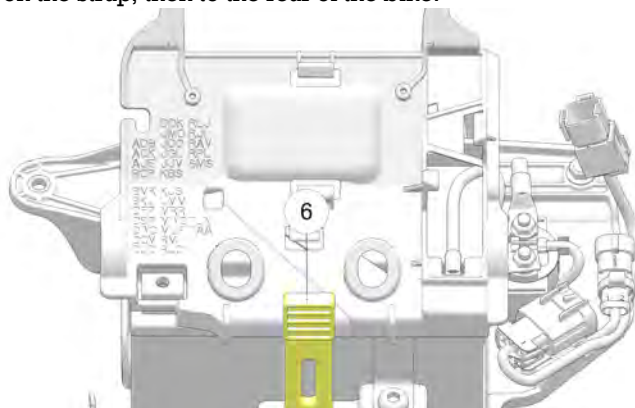

7. Lift the rear of the upper battery tray upward and pull it toward the rear of the unit to remove.

8. Disconnect the positive (+) battery cable ⑦ and remove the cable from the terminal. Position the cable well clear of the terminal.

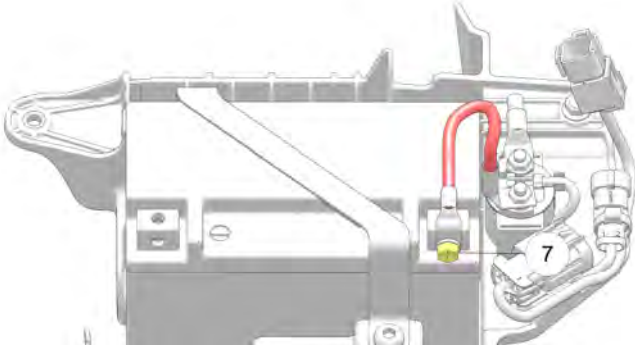

9. Remove the fastener ⑧ securing the battery strap ⑨.

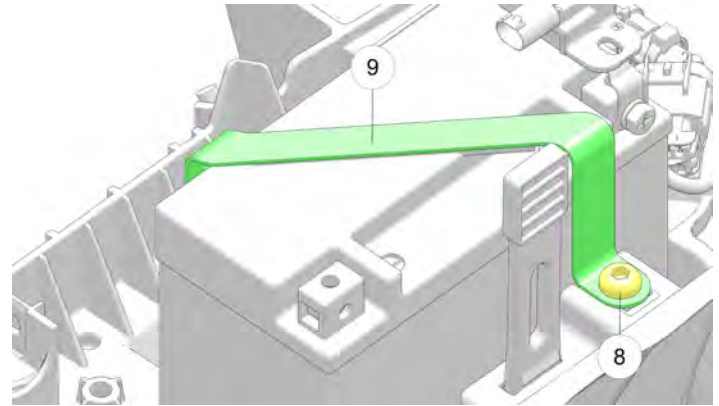

## MAINTENANCE

10. Remove the battery strap by moving the front of the strap forward out of the retention feature of the battery box.

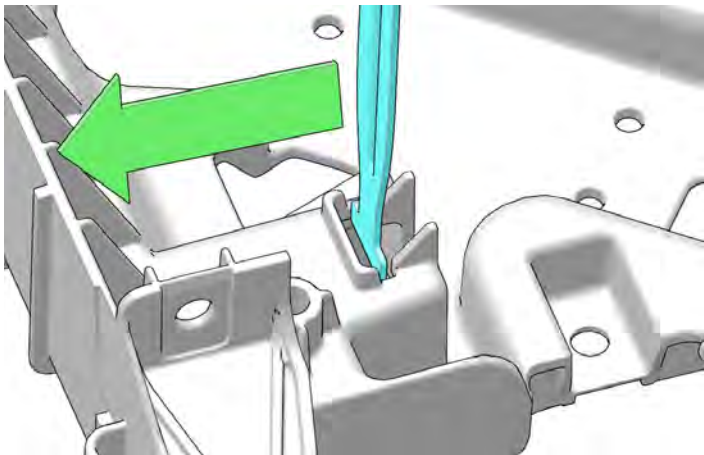

11. Lift the battery from the battery box.

## BATTERY INSTALLATION

### WARNING

Improperly connecting or disconnecting battery cables can result in an explosion and cause serious injury or death. When removing the battery, always disconnect the negative (black) cable first. When reinstalling the battery, always connect the negative (black) cable last.

### NOTICE

Do not remove the battery cables while the engine is running. Doing so may damage the Engine Control Unit (ECU). Take great care not to reverse the battery leads when installing the battery. Reverse power applied to the ECU will damage it instantly.

1. Inspect the battery box and cover for damage. Be sure pads are in good condition and properly located.
2. Make sure cable ends and battery terminals are clean. Apply a light film of dielectric grease to the terminal bolt threads.
3. Carefully position the battery into the battery box with both terminals toward the rear of the bike.



4. Make sure the positive (+) cable ① is routed horizontally and parallel to the short side of the battery. Connect the positive (+) cable to the positive (+) battery terminal.

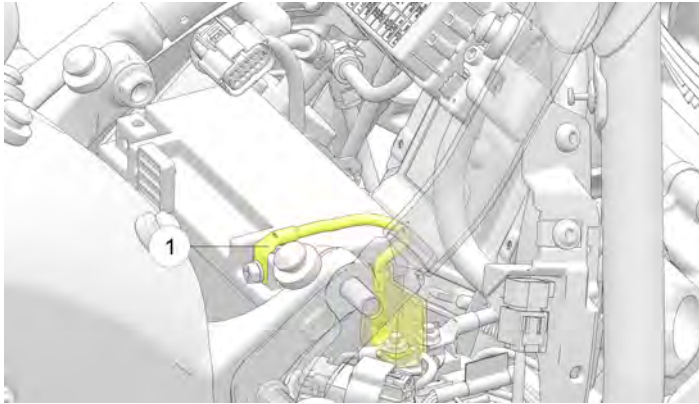

### TORQUE

45 in-lbs (5 Nm)

5. Check the positive (+) cable ① to ensure it is not pinched or wedged between the frame and battery tray.

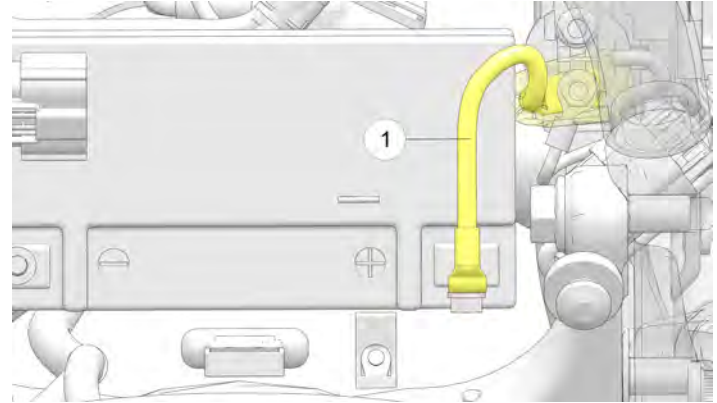

## MAINTENANCE

6. Insert the battery hold down strap into the battery box retention slot and slide the strap towards the rear of the bike.

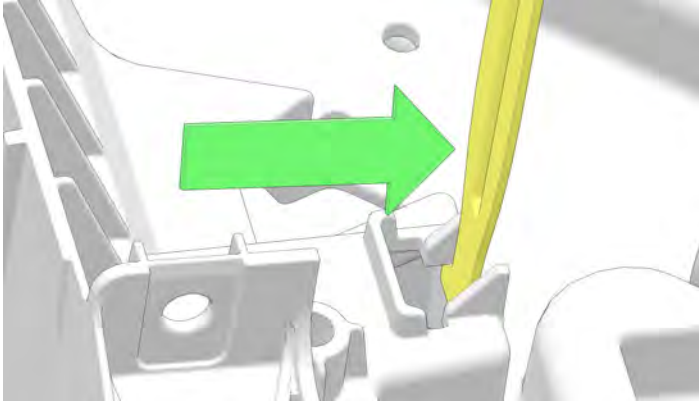

7. Install the battery hold down strap fastener<sup>③</sup> through the battery hold down strap<sup>②</sup>.

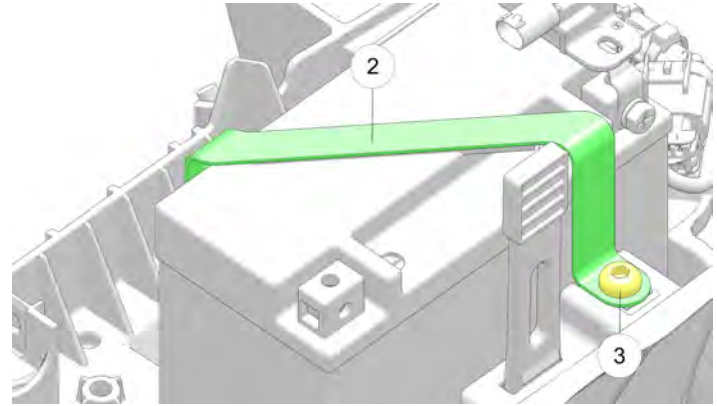

**TORQUE**

84 in-lbs (9.5 Nm)

8. Install the battery cover. Secure the cover with the cover strap ④.

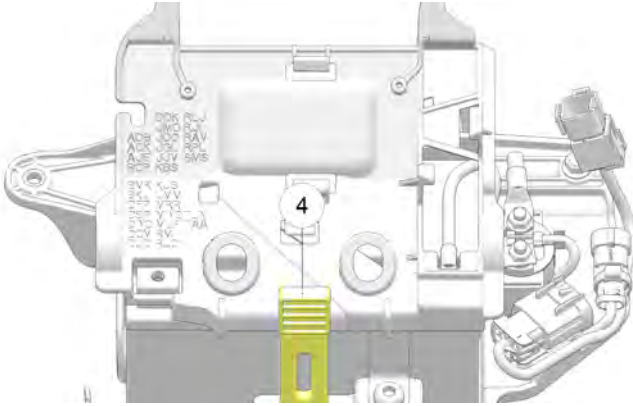

9. Install the negative (-) cable ⑤. Route the starter ground cable beneath the frame ground cable on the negative battery terminal.

### TORQUE

45 in-lbs (5 Nm)

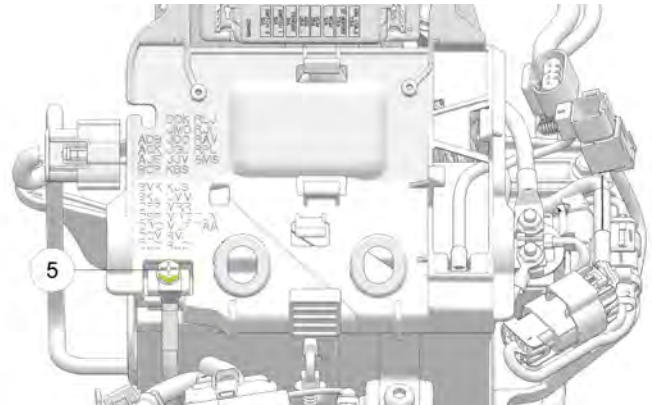

## MAINTENANCE

---

10. Install the antenna wiring harness onto the upper battery tray. Make sure that the wiring harness is secured in both retention areas.

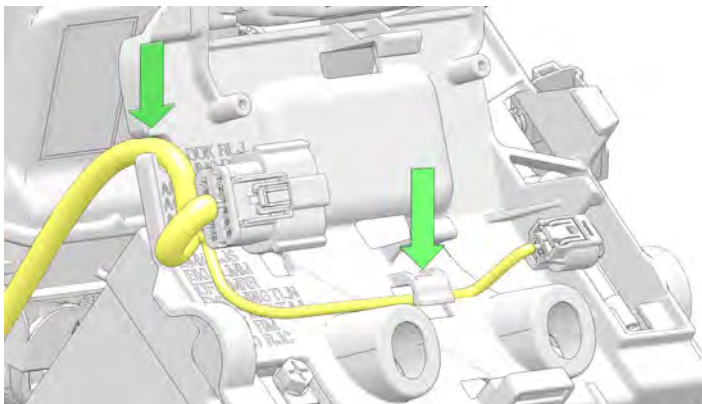

11. Install the antenna ⑥ onto the upper battery tray. Connect the antenna harness ⑦ to the antenna.

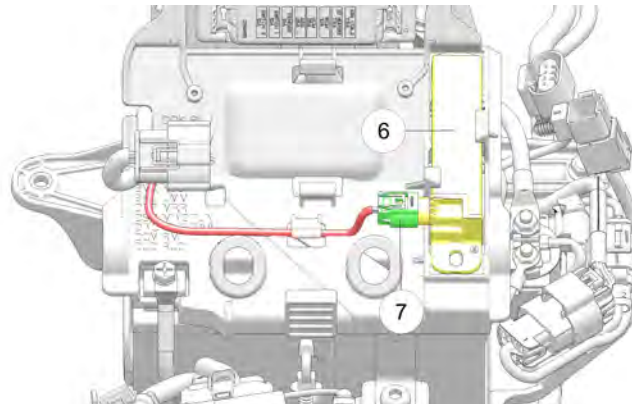

12. Install the Wireless Control Module (WCM) ⑧ onto the upper battery tray. Connect the main harness ⑨ to the WCM.

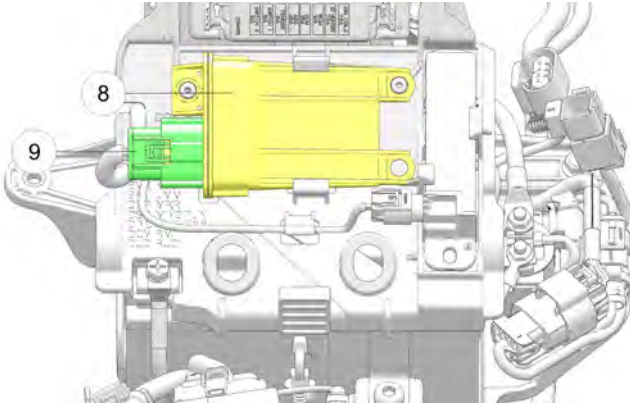

13. Reinstall the seat. See page 135.

## BATTERY CHARGING

If your motorcycle will not be used for a period of four (4) weeks or longer, a maintenance charger should be connected to the battery using the Battery Charge Port. A maintenance charger can be purchased through your authorized INDIAN MOTORCYCLE dealer.

### NOTICE

Before connecting a battery charger to the Battery Charge Port, ensure the vehicle has cooled to ambient temperature. Do not allow cables to rest on hot or sharp surfaces while charging.

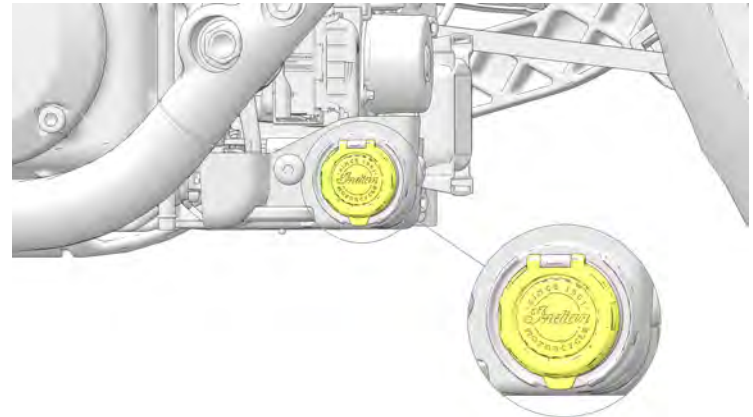

## MAINTENANCE

---

1. Following the charger manufacturer's instructions, use a battery charger designed for use with 12-volt batteries. The charger should have a maximum charging rate of 1.8 amps. Charge the battery for approximately 10 hours at a rate of 1.8 amps. If you use a taper or trickle charger, it will take longer to charge the battery.
2. After charging the battery, allow the battery to sit 1-2 hours before checking the state of charge with a DC volt meter. The charge should be a minimum of 12.5 DC volts. Repeat the charging cycle if the charge is less than 12.5 DC volts. Replace the battery if it fails to reach 12.5 volts after the second charge.

## BATTERY CHARGING AND MAINTENANCE

### IMPORTANT

Read and follow the safety precautions listed on the battery and the proper battery charging procedures outlined in the Owner's Manual.

## AGM BATTERY CHARGER RECOMMENDATIONS

Indian Motorcycle recommends using the BatteryMINDER® 2012 AGM - 2 AMP battery charger (PN 2830438) to charge and maintain AGM batteries. The charger can be found on the Polaris PG&A website.

Batteries that fall below 12.5V run the risk of sulfation, a condition whereby sulfate crystals form inside the battery and significantly reduce performance. AGM chargers are designed specifically for charging AGM type batteries and use high frequency pulses to partially reverse sulfation.

### IMPORTANT

The use of non-AGM battery chargers may result in a misleading "battery not found" or "open cell" fault message. Please ensure you are using the recommended AGM charger when charging AGM type batteries.

## AGM BATTERY CHARGING RECOMMENDATIONS - LOW CHARGE

The nominal voltage for an Indian Motorcycle battery is 12.8 Volts when fully charged. The battery will self-discharge when disconnected from a vehicle, and will discharge at a faster rate when connected. If the battery voltage falls below 12.5V, it should be charged immediately using the recommended battery charger.

Batteries which are not connected to a vehicle should be inspected every 2-3 months. The battery must be charged if found to be below 12.5 volts.

Always use the recommended automatic battery charger, and wait for the charger to complete the charge cycle before disconnecting it.

## AGM BATTERY CHARGING RECOMMENDATIONS – DEEPLY DISCHARGED (BELOW 3 VOLTS)

AGM batteries discharged to a voltage of 3 volts or less may not be recognized by the recommended automatic battery charger. (The minimum voltage threshold recognized by other battery chargers may be as high as 10.5 volts). Often times deeply discharged batteries can be restored by attaching another, fully-charged, battery to “jump start” the low battery. Follow the steps below to restore a deeply discharged battery.

1. Carefully connect the two batteries’ positive terminals, then the negative terminals using jumper cables.
2. Connect the recommended battery charger to the low battery and initiate the charging sequence.

|   |
|---|
|  <b>WARNING</b>  |
| Always check to ensure the positive cables are connected to the positive terminals before powering the charger on. Reversing polarity when charging can damage electrical components and risk personal injury. Be careful not to let battery cable clamps touch each other. |

3. After the charging sequence has initiated, disconnect the fully-charged battery. Always disconnect the fully-charged battery positive first, followed by low battery positive, low battery negative, and finally fully-charged battery negative
4. Proceed with charging both batteries to full capacity. Listed in the table below are the approximate charging times for deeply discharged batteries. Always use the recommended automatic battery charger, and wait for the charger to complete the charge cycle before disconnecting it. The recommended automatic charger will indicate when the battery is fully charged on its display.

## AGM BATTERY CHARGING RECOMMENDATIONS TABLE

| STATE OF CHARGE | VOLTAGE (DC) | ACTION   | RECOMMENDED CHARGE TIME* |
|-----------------|--------------|--|--------------------------|
| 100%            | 12.8-13.2 V  | None   | None Required            |
| 75%-100%        | 12.6-12.8 V  | May need slight charge<br>If no charge given, check again within 4 weeks | 2-4 Hours                |

## MAINTENANCE

| STATE OF CHARGE                   | VOLTAGE (DC)  | ACTION       | RECOMMENDED CHARGE TIME* |
|-----------------------------------|---------------|--------------|--------------------------|
| 50%-75%                           | 12.3-12.6V    | Needs Charge | 4-6 Hours                |
| 25%-50%                           | 12.0-12.3V    | Needs Charge | 6-8 Hours                |
| 0%-25%                            | 12.0V or less | Needs Charge | At Least 8 Hours         |
| *Assuming 2 Amps constant current |               |              |                          |

### AGM BATTERY MAINTENANCE TIPS

1. If the motorcycle will not be driven for more than 2 weeks, maintaining the battery with the BatteryMINDER® 2012-AGM charger (PN 2830438) is recommended.
2. To help prolong battery life, it is recommended to remove the battery from vehicles stored ONE month or longer. To maximize the life of stored batteries, they should be kept in a cool/dry location. Batteries will self discharge more rapidly when stored in extreme temperatures. Batteries should be maintained using the recommended battery charger while in storage.

3. Batteries will self-discharge more quickly when dirty. Periodic cleaning of the battery terminals using a terminal brush will help maximize battery life. Wash terminals with a solution of one tablespoon baking soda and one cup water. Rinse well with tap water and dry off with clean shop towels. Coat the terminals with dielectric grease or petroleum jelly.
4. Battery connections should be tightened to the correct torque during installation. This will reduce voltage drop and ensure a reliable connection between the regulator/rectifier and battery.

### FUSE REPLACEMENT

#### NOTICE

Use fuses with the recommended amperage to avoid damage to the electrical system.

### STANDARD FUSES

The standard fuse box is located under the seat. This fuse box houses all standard service fuses and the automatic circuit breakers. Fuse application and size are provided on a label on the fuse box cover.

#### TIP

Use the fuse puller provided in the tool kit to remove a fuse.



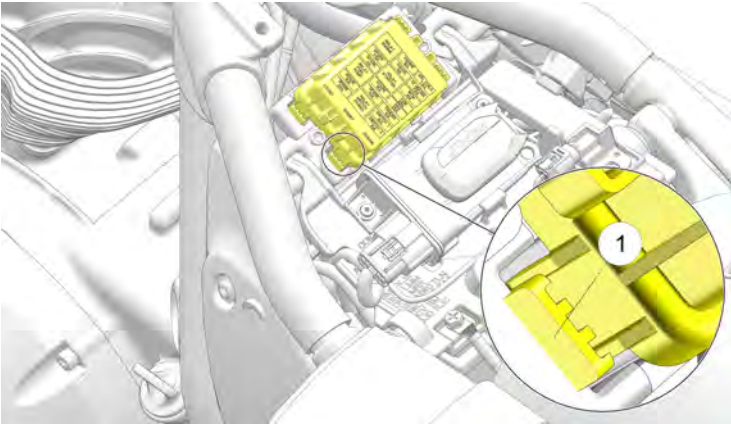

1. Remove the seat. See page 134
2. To release the locking tabs, squeeze the upper and lower cover clips ① and remove the fuse box cover.
3. After replacing a fuse, reinstall the fuse box cover and side cover.

## HIGH-CURRENT FUSES

The JCASE® fuse box ① contains the high-current fuses for the chassis, vehicle control module and anti-lock brake system. This fuse box is located under the motorcycle, next to the charging port.

Fuse application and size are provided on a label on the fuse box cover.

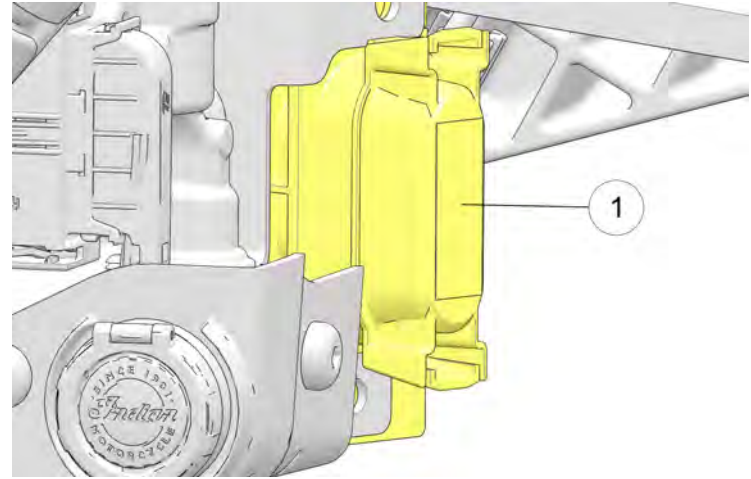

## ELECTRICAL PRECAUTIONS

Be aware of the following precautions regarding the electrical system to avoid disruption of electrical signals and possible system malfunction.

- DO use ONLY genuine INDIAN MOTORCYCLE parts and accessories designed for your model, and follow the instructions provided.
- DO use the accessory power jack provided (if equipped).

## MAINTENANCE

---

- If it is necessary to provide power to an item that does not use one of the previously mentioned power jacks, connect to the load side of the main circuit breaker and connect the ground wire to the engine ground at the front left side of the crankcase (near the circuit breaker). On DARK HORSE models the circuit breaker is located under the cover next to the oil filter adapter. On all other models it's located under the cover behind the oil cooler.
- DO NOT splice or cut any wires.
- DO NOT tap in to any power or ground on the motorcycle unless specifically directed to do so by the INDIAN MOTORCYCLE instructions that come with the kit.
- DO NOT back-probe electrical connectors on the vehicle unless directed to do so by the *INDIAN MOTORCYCLE Service Manual*.
- DO NOT power any accessories from the diagnostic connector (under left side cover).

### UNLOCKING THE SECURITY SYSTEM (BASE MODELS ONLY)

Your dealer will provide the master personal identification number (PIN) for the security system. Your dealer may also change the master PIN to a new rider PIN on your behalf.

Record both PINs on page 7.

Change the dealer-provided PIN to a PIN of your own choosing as soon as possible after receiving delivery of your new motorcycle. See page 153.

If a key fob is not available, your rider PIN can be entered using the turn signal switches to unlock the security system. Use the following guide to enter your valid rider PIN.

| DIGIT TO ENTER  | TURN SIGNAL FEATURE USED | PROCEDURE   |
|---|--------------------------|---|
| The number "0"  | CANCEL switch            | Press and release   |
| First digit (1-9)   | LEFT turn switch         | Move and release once per digit value. See example below. |
| Second digit (1-9)  | RIGHT turn switch        |   |
| Third digit (1-9)   | LEFT turn switch         |   |
| Fourth digit (1-9)  | RIGHT turn switch        |   |
| <b>Example for entering the number 1024:</b><br>LEFT - CANCEL - LEFT - LEFT - RIGHT - RIGHT - RIGHT - RIGHT |                          |   |

### UNLOCKING THE SECURITY SYSTEM (PREMIUM MODELS ONLY)

Your dealer will provide the master personal identification number (PIN) for the security system. Your dealer may also change the master PIN to a new rider PIN on your behalf.

Record both PINs on page 7.

Change the dealer-provided PIN to a PIN of your own choosing as soon as possible after receiving delivery of your new motorcycle. See page 154.

If a key fob is not available, your rider PIN can be entered using the digital display to unlock the security system.



## CHANGING YOUR SECURITY SYSTEM PIN (BASE MODELS ONLY)

To change your PIN, you must have either the key fob or your existing valid PIN available to gain access to the security system. If the key fob is not detected or is not available and you cannot remember your PIN, please see your INDIAN MOTORCYCLE dealer.

Please read the entire procedure before beginning.

1. Turn the power switch on. Do NOT start the engine. The security light and/or power switch will turn on briefly until the key fob is detected or until the valid, current PIN is entered.
2. Push or hold the turn signal CANCEL switch for 10 seconds until the security light and/or power switch turn on.
3. Enter either the master PIN (see page 7) or your current 4-digit rider PIN within 20 seconds. If the PIN is successfully entered, the security light and/or power switch will remain on and the horn will sound briefly.

### NOTICE

If the valid PIN is not entered within 20 seconds, the security light and/or power switch will flash for 10 seconds, then the system will shut down. Return to step 1 to try again.

## MAINTENANCE

---

4. Enter a new 4-digit security PIN of your own choosing. If the PIN is successfully entered, the security light will remain on and the horn will sound briefly. Proceed to step 5.

### NOTICE

If the 4-digit PIN is NOT successfully entered within 20 seconds, the security light will flash for 10 seconds, then the system exits the procedure. Return to step 1 to try again.

5. Re-enter the new 4-digit PIN. If this entry matches the first entry, the security light will turn off and the horn will sound briefly. The new rider PIN has been saved. *Record your new rider PIN on page 7.*

### NOTICE

If the second entry is not entered within 20 seconds or does not match the first entry, the security light will flash for 10 seconds, then the system exits the procedure. The new PIN was NOT saved. Continue to use your former valid PIN. Return to step 1 to try again.

## CHANGING YOUR SECURITY SYSTEM PIN (PREMIUM MODELS ONLY)

To change your PIN, you must have either the key fob or your existing valid PIN available to gain access to the security system. If the key fob is not detected or is not available and you cannot remember your PIN, please see your INDIAN MOTORCYCLE dealer.

Please read the entire procedure before beginning.

1. Tap “Change Passcode” on the display screen.
2. Enter an existing or master PIN by pressing the corresponding numbers on the display screen.
3. When prompted, enter a new PIN into the display screen. When complete, press the arrow button.
4. When prompted, enter the new PIN into the display screen to confirm the PIN.
5. If the PIN has been accepted, the display screen will display a confirmation.

## ENGINE COMPRESSION TEST

An engine compression test can be performed to monitor general engine condition. See the *INDIAN MOTORCYCLE Service Manual* or an authorized INDIAN MOTORCYCLE dealer can assist.

## EXHAUST SYSTEM INSPECTION

Check the exhaust system for stains from leaking exhaust gasses. Replace damaged or leaking exhaust gaskets. Check all exhaust system fasteners. Tighten loose clamps and fasteners. Do not overtighten. See the *INDIAN MOTORCYCLE Service Manual* or an authorized INDIAN MOTORCYCLE dealer can assist.

Check the six heat shield clamps on the exhaust pipes. Torque each clamp to specification.

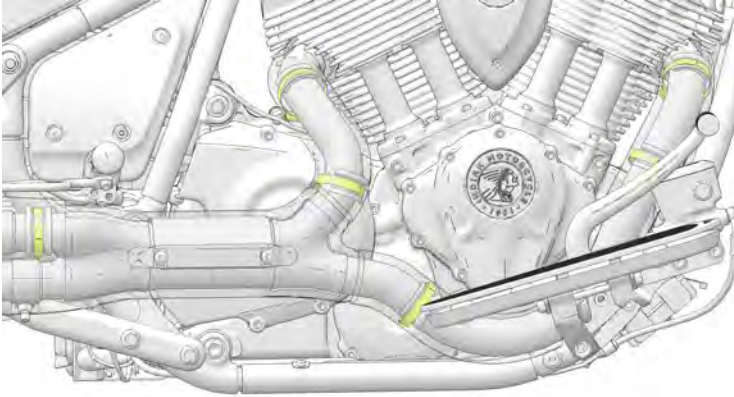

**TORQUE**

31 in-lbs (3.5 Nm)

Check the two heat shield fasteners ① on the exhaust pipes. Torque each fastener to specification.

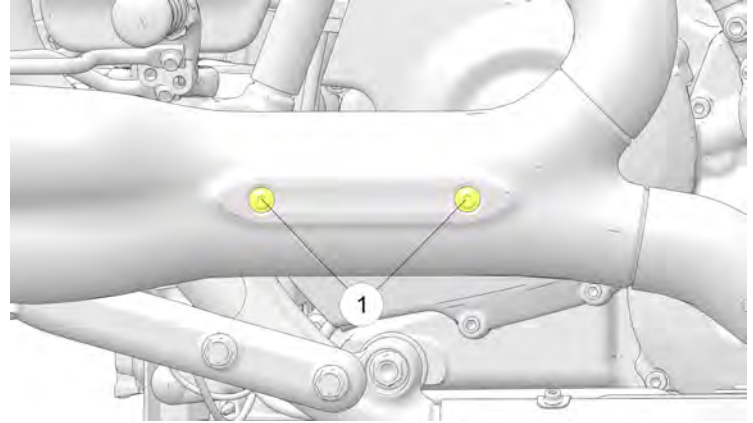

**TORQUE**

7.4 ft-lbs (10 Nm)

## MAINTENANCE

Check the two muffler clamps ①. Torque each clamp to specification.

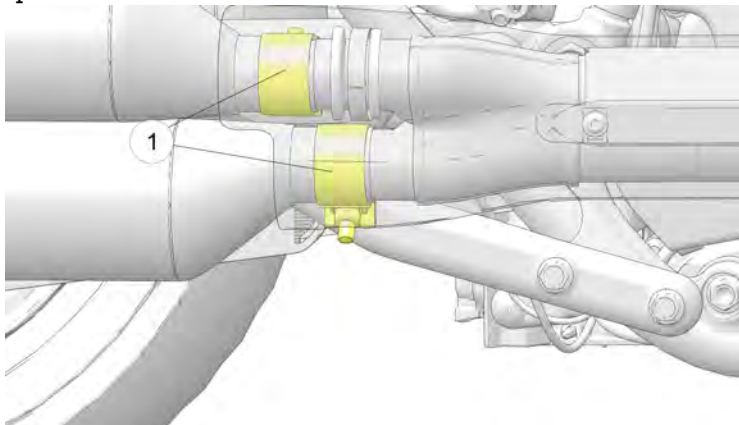

**TORQUE**

40.5 ft-lbs (55 Nm)

Check the two muffler fasteners ① on the exhaust support. Torque each fastener to specification.

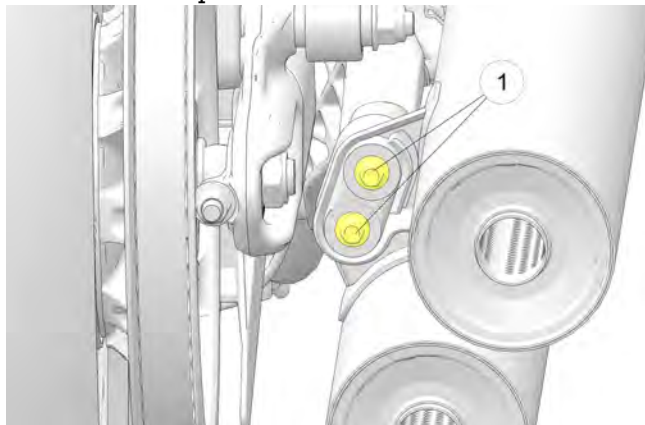

**TORQUE**

18.4 ft-lbs (25 Nm)

Check the 4 exhaust header nuts ① on the cylinder head. Torque each fastener to specification.

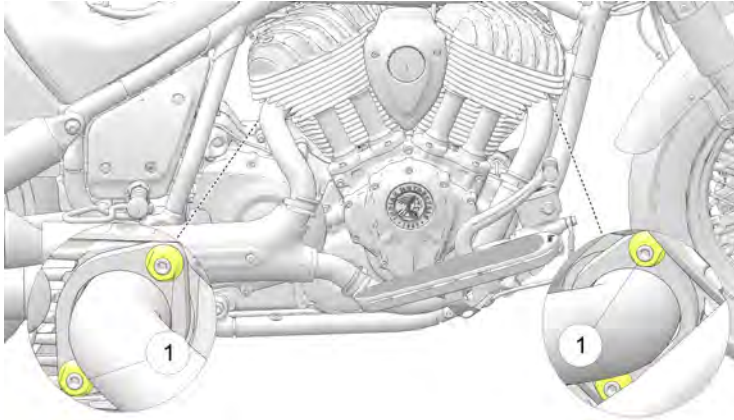

**TORQUE**

15.1 ft-lbs (3.5 Nm)

**ELEVATING THE MOTORCYCLE**



Serious injury or death can occur if the motorcycle tips or falls. Make sure the motorcycle will not tip or fall while elevated or while on the sidestand.

Some procedures require raising the motorcycle to remove weight from the component being inspected. Elevate the motorcycle by placing a stable, flat platform jack or lift mechanism on a firm, flat surface and lifting under the engine crankcase. The platform should be a minimum of 12 in (30 cm) square. DO NOT attempt to lift the motorcycle without proper equipment. Always secure the motorcycle properly before lifting so it cannot tip or fall when elevated.

**ROAD TEST**

Before returning the motorcycle to regular use, perform a road test in a safe area. Pay special attention to the proper fit and operation of all serviced components.

Make any corrections or additional adjustments promptly to ensure safe, reliable and enjoyable vehicle performance.

**FASTENER INSPECTION**

1. Inspect the entire motorcycle chassis and engine for loose, damaged or missing fasteners. Tighten loose fasteners to the proper torque. See the *INDIAN MOTORCYCLE Service Manual* or an authorized INDIAN MOTORCYCLE dealer can assist.
2. Always replace stripped, damaged or broken fasteners before riding. Use genuine INDIAN MOTORCYCLE fasteners of equal size and strength.

**FASTENER TORQUES**

Some procedures and fastener torques are not listed in this manual. See the *INDIAN MOTORCYCLE Service Manual* or an authorized INDIAN MOTORCYCLE dealer can assist.

## MAINTENANCE

### TROUBLESHOOTING

For your personal safety, do not attempt inspection or repairs not fully described in this rider's manual. Contact an authorized dealer for service if you cannot determine the cause of a problem or if the inspection/repair exceeds your mechanical ability or tool resources. Do not perform any inspection or repair with the engine running.

#### ENGINE CRANKS BUT WILL NOT START

| POSSIBLE CAUSE                           | POSSIBLE REMEDY/ACTION  |
|--|---|
| Low Fuel                                 | Verify fuel level.  |
| Fuel Pump Inoperative                    | Turn engine STOP switch to RUN. Turn the power switch on. The fuel pump should run momentarily and then stop. Check the fuel pump/ignition circuit breaker. |
| Battery Voltage Too Low                  | Fully charge the battery.   |
| Spark Plug(s) Fouled                     | Inspect spark plugs.  |
| Spark Plug Wire(s) Disconnected or Loose | Be sure spark plug wires are securely fastened.   |
| Low Compression                          | Please see your dealer for an engine compression test.  |

#### STARTER MOTOR CLICKS, DOES NOT TURN OR TURNS SLOWLY

| POSSIBLE CAUSE                              | POSSIBLE REMEDY/ACTION   |
|---|--|
| Engine Stop/Run Switch in Stop Position     | Place switch in RUN position.  |
| Battery Discharged                          | Fully charge the battery.  |
| Battery Cables Loose or Corroded            | Inspect battery cables.  |
| Transmission In Gear                        | Shift transmission into neutral or pull the clutch lever in to disengage the clutch. |
| Key Fob Not Authenticated                   | Make sure key fob is within range and that key fob battery voltage is not low.       |
| Sidestand is Down With Transmission in Gear | Shift to neutral or retract the sidestand fully.                                     |

#### ENGINE STARTS BUT MISSES OR RUNS POORLY

##### NOTICE

Turn engine OFF before inspecting any of these items.

| POSSIBLE CAUSE                   | POSSIBLE REMEDY/ACTION                       |
|----------------------------------|--|
| Battery Discharged               | Fully charge the battery.                    |
| Battery Cables Loose or Corroded | Inspect battery cables and connections.      |
| Spark Plug(s) Fouled             | Inspect spark plugs.                         |
| Spark Plug Wire(s) Loose or Wet  | Inspect spark plug wires, ensure dry/secure. |



| POSSIBLE CAUSE                             | POSSIBLE REMEDY/ACTION  |
|--|---|
| Contaminated Fuel                          | Inspect fuel for water/contamination. Please see your dealer.           |
| Engine Oil Level Incorrect Or Wrong Type   | Inspect level and quality of oil.                                       |
| Loose, Broken, Shorted Ignition Coil Wires | Inspect coil primary wires. Please see your dealer.                     |
| Air Intake Restricted                      | Inspect air filter.   |
| Intake Leaks                               | Inspect air box, throttle body, fuel injectors, and intake boot joints. |

## BATTERY CHARGING RATE LOW OR BATTERY DISCHARGES

| POSSIBLE CAUSE                             | POSSIBLE REMEDY/ACTION   |
|--|--|
| Loose/Corroded Charging Circuit Connection | Check/clean battery cable connections. Check/clean charging circuit connections. Please see your dealer. |
| Accessory Load Exceeds Charge Rate         | Limit accessory operation when the engine is off.  |
| Improperly Wired Accessory (Current Draw)  | Please see your dealer to check charging system output and current draw.                                 |

## SHIFTING DIFFICULTIES OR HARD TO FIND NEUTRAL

| POSSIBLE CAUSE                      | POSSIBLE REMEDY/ACTION                                |
|-------------------------------------|---|
| Shift Linkage Bushings Dry Or Worn  | Lubricate shift linkage.                              |
| Clutch Damage                       | Replace clutch.                                       |
| Clutch Cable Not Adjusted Properly  | Please see your dealer for inspection and adjustment. |
| Shift Linkage Not Adjusted Properly | Please see your dealer for inspection and adjustment. |

## BRAKE NOISE/POOR BRAKE PERFORMANCE

| NOTICE  |
|---|
| See your dealer if brake performance does not return after these inspections. |

| POSSIBLE CAUSE                              | POSSIBLE REMEDY/ACTION               |
|---|--------------------------------------|
| Dust/Dirt On Brake Disc(s)                  | Clean disc.                          |
| Worn Pads Or Disc/Brake Disc Damage         | Inspect pads.                        |
| Brake Fluid Level Low Or Fluid Contaminated | Inspect fluid level/fluid condition. |

### **ANTI-LOCK BRAKE LIGHT REMAINS ILLUMINATED OR ILLUMINATES INTERMITTENTLY**

| <b>POSSIBLE CAUSE</b>   | <b>POSSIBLE REMEDY/ACTION</b>                   |
|-------------------------|---|
| Blown fuse              | Check the fuses. See page 150.                  |
| Damage caused by debris | Inspect wheel speed sensor and wire for damage. |
| Damaged components      | See service manual or authorized dealer.        |

## CLEANING AND STORAGE

### CLEANING PRODUCTS

This section provides tips on the very best way to clean, polish and preserve every surface of your beautiful new INDIAN MOTORCYCLE. We recommend the use of our new INDIAN MOTORCYCLE cleaning and polishing products and accessories, which have been specially designed to offer the best care possible for your INDIAN MOTORCYCLE.

In addition to the products recommended in this section for cleaning and polishing, INDIAN MOTORCYCLE also has specialty products for:

- enhancing black and silver engines
- cleaning engines, tires and wheels
- removing brake dust

After cleaning the motorcycle, inspect for damage to the painted surfaces. Chips or scratches should be repaired promptly to prevent corrosion.

For Matte Clear Coat Finish Care, see the *Matte Clear Coat Finish Care* section for details.

For Gloss Clear Coat Finish Care, see the *Gloss Clear Coat Finish Care* section for details.

For more information, or for answers to your cleaning and detailing questions, please see your INDIAN MOTORCYCLE dealer.

## WASHING THE MOTORCYCLE

### NOTICE

Do not use pressurized water to wash the motorcycle. Water may seep in and deteriorate wheel bearings, brake caliper assemblies, brake master cylinders, electrical connectors, steering head bearings, and transmission seals. Do not direct any water stream at air intakes, exhaust outlets, electrical connectors or audio system speakers. Electrical components may be damaged by water. Do not allow water to contact electrical components or connectors.

1. Before washing, make sure exhaust pipes are cool. Cover each pipe opening with a plastic bag secured with a strong rubber band. Check that the spark plugs, spark plug wire caps, oil fill cap and fuel caps are properly seated. Cover or remove the saddle bags.
2. Do not use abrasive cleaners.
3. Rinse off as much dirt and mud as possible with water running at low pressure. Use as little water as possible when washing near the air intake or the exhaust pipe openings. Dry these components thoroughly before using the motorcycle.
4. Clean the front fork tubes thoroughly to reduce fork seal wear and leakage.

## CLEANING AND STORAGE

---

5. After washing, remove the rubber bands and plastic bags from the exhaust pipes. Start the engine and let it idle for a few minutes.
6. Make sure the brakes are functioning properly before riding.

### WINDSHIELD CARE (IF EQUIPPED)

Clean the windshield with a soft cloth and plenty of warm water. Dry with a soft clean cloth. Remove minor scratches with a high-quality polishing compound designed for use on polycarbonate surfaces.

#### NOTICE

Brake fluid and alcohol will permanently damage the windshield. Do not use glass cleaners, water or soil repellents, and petroleum or alcohol based cleaners on the windshield, as these products can damage the windshield.

### MATTE CLEAR COAT FINISH CARE

Matte finish products are prone to trapping dirt, oils and other contaminants. Always clean this type of finish with warm water and a mild dish-washing detergent. Use a soft sponge to gently rub the surface, then rinse with clean warm water. For stubborn stains such as grease or oil, use a citrus-based cleaner. Spray the cleaner onto the area and rub gently with a soft sponge. Allow the cleaner to sit for a couple of minutes, then rinse well with clean warm water. Repeat as needed.

#### NOTICE

Never use a polishing/buffing wax or any sponge that has an abrasive surface when cleaning a matte finish. These products will buff the matte surface of the finish and result in a glossy finish. Never clean matte finishes with a pressure washer, as this will further imbed contaminants into the clear coat and may damage labels and decals.

### GLOSS CLEAR COAT FINISH CARE

The clear coat finish system used on all INDIAN MOTORCYCLE provides superior protection against the elements. To maximize the benefits of this system, use the following guide to care for the gloss finish on your motorcycle.

- During the first 30 days, when the finish is still fresh, clean the motorcycle with a water rinse only.
- Do not wax the motorcycle for the first 60 days. Doing so can cause loss of the gloss. After 60 days, use only waxes designed for new clear coat finishes.
- Do not use pressurized water to wash the motorcycle. When paint is still fresh, pressurized water could damage the finish. If using a pressure washer is unavoidable, keep the spray nozzle at least 24 inches (60 cm) away from the surface of the motorcycle.
- Wash your motorcycle often, especially when exposed to salty, dusty, acidic or alkaline environments.
- Use warm or cool water and a soft cloth for cleaning.
- Use soaps that are non-abrasive and have a neutral pH (non acidic/non alkaline detergents).

- Do not use solvent-based solutions.
- Do not use a dry cloth to remove dust.
- Do not use a stiff bristle brush, which can scratch the surface.
- Do not wash with extremely hot water.
- Do not wash the motorcycle while the surface is hot and avoid washing the motorcycle in the hot sun. Minerals in the water may be difficult to remove once dried on the surface of the motorcycle.
- Do not allow spilled gasoline, motor oil or brake fluid to stand on the paint. Remove these substances immediately by rinsing with water. Use a soft cloth to absorb any remaining residue and dab dry.
- To remove bug remnants or road tar, use only products that are specifically designed for this purpose. Follow the product manufacturer's recommendations to prevent potential damage to the finish. Follow with a wash using the methods described in this section.
- Always brush away any ice or snow, do not scrape off.
- Chips or scratches should be repaired promptly to prevent corrosion.

### INFOTAINMENT TOUCHSCREEN CARE

We recommend using a gentle detergent and water to clean your touchscreen. Wash and dry with a lint free cloth.

- Do not expose to brake fluid.
- Do not expose to gasoline.
- Do not expose to DEET.

### STORAGE AREA PREPARATION

If you will not operate the motorcycle for more than 60 days, store the motorcycle to prevent damage to the fuel system and the battery and to protect components from corrosion or deterioration. During storage preparation you might use products that are potentially hazardous; such as fuel stabilizer. When using any of these products, follow the instructions and warnings on the product packaging.

Choose a dry, well-ventilated storage location, inside a garage or other structure if possible. The location should have a firm, flat surface and allow enough space for the motorcycle.

#### WARNING

Gasoline is highly flammable and explosive under certain conditions. Do not store the motorcycle in any area (in home or garage) where it could be near open flames, pilot lights, sparks or electric motors. Do not smoke in the storage area.

To best preserve tire condition:

- The storage area should have a relatively constant and moderate temperature.
- The storage surface should be free of oil and gasoline.
- The motorcycle should not be near a radiator or other heat source, or any type of electric motor.

## CLEANING AND STORAGE

---

### CLEAN AND PROTECT THE MOTORCYCLE

To prepare the motorcycle for storage, begin by cleaning and polishing the motorcycle as outlined beginning on page 161. Polish chromed and other metal surfaces. Apply protectant to exposed rubber, vinyl and plastic parts. *Do not apply rubber protectant to the tire tread surfaces.*

### FUEL STABILIZER

Add fresh fuel to fill the fuel tank and add fuel stabilizer. Do not overfill.

Ride the motorcycle or start and run the engine for 15 minutes in a well ventilated area to distribute the stabilizer throughout the fuel system.

### TIRE INFLATION

Inflate the tires to normal pressure. See .

### ENGINE PROTECTION

Change the engine oil.

### BATTERY CARE

1. Remove the battery. See page 138.
2. Clean the battery terminals first with a wire brush to remove any loose deposits.
3. Wash the posts and the ends of the battery cables with a solution of one part baking soda to 16 parts water. Rinse with clean water and wipe dry.

4. Apply a thin film of dielectric grease to the posts and cable connectors.
5. Clean the outside of the battery with a solution of mild detergent and warm water.
6. Store the battery in a dry area with a temperature of 32° to 90° F (0° to 32° C).
7. While in storage, fully charge the battery once a month. See page 147.

### MAINTENANCE DURING STORAGE

During extended storage periods, maintain tire pressure and battery voltage at the recommended levels.

### RODENTS

Mice and other rodents are often the worst enemy of a stored motorcycle. If the motorcycle will be stored in an area where mice are a concern (particularly in rural areas, barns, sheds, etc.) be sure to take extra measures to deter their infestation. This may include placing a screen mesh over any intake or exhaust openings (remember to remove them when you remove the motorcycle from storage).

## PARK AND COVER THE MOTORCYCLE

1. Park the motorcycle in its storage location. Block the frame to take some of the weight off the front and rear wheels.

### NOTICE

Starting the motorcycle periodically during storage is **NOT** recommended. Water vapor is a by-product of the combustion process, and corrosion may result unless the engine is operated long enough to bring the oil and exhaust system to normal operating temperature.

2. Secure a plastic bag over the (cooled) exhaust outlets to prevent moisture from entering the exhaust system.
3. Cover the motorcycle with a cover made from a durable, breathable material designed for storage. Covering the motorcycle helps protect it from dust and other airborne materials. The cover must be of a breathable material to prevent moisture from building up on the motorcycle which can cause oxidation of metal surfaces.

## REMOVAL FROM STORAGE

1. Install a fully charged battery.
2. Check the oil level. If the motorcycle was stored in an area subject to wide swings in temperature and humidity (such as outdoors), change the engine oil before starting the engine.

### NOTICE

During storage, temperature and humidity changes can cause condensation to form in the crankcase and mix with engine oil. Running the engine with oil that contains condensation can cause engine damage.

3. Inspect the storage area for signs of fluid leaks. Identify and perform service to any leaking components.
4. Remove any intake or exhaust mesh covers installed for rodent protection.
5. Install new spark plugs if necessary.
6. Perform the pre-ride inspections outlined in this manual.
7. Perform a road test. See page 157.
8. Wash and polish the motorcycle. Wax, polish or apply protectant to appropriate components.





**SPECIFICATIONS**  
**DIMENSIONS**

Dimensions and specifications may vary with features, options and accessories.

|                    | <b>CHIEF MODELS</b>    | <b>CHIEF BOBBER MODELS</b> | <b>SUPER CHIEF MODELS</b> |
|--------------------|------------------------|----------------------------|---------------------------|
| Overall Length     | 90.0 in. (2286 mm)     | 90.0 in. (2286 mm)         | 90.0 in. (2286 mm)        |
| Overall Width      | 36.3 in. (922 mm)      | 36.0 in. (915 mm)          | 42.5 in. (1079 mm)        |
| Overall Height     | 49.3 in. (1253 mm)     | 53.1 in. (1349 mm)         | 55.9 in. (1421 mm)        |
| Seat Height        | 27.2 in. (690 mm)      | 27.2 in. (690 mm)          | 27.4 in. (695 mm)         |
| Wheelbase          | 64.0 in. (1626 mm)     | 64.0 in. (1626 mm)         | 64.0 in. (1626 mm)        |
| Ground Clearance   | 4.9 in. (125 mm)       | 4.9 in. (125 mm)           | 4.9 in. (125 mm)          |
| Rake (frame)/Trail | 29°/5.2 in. (131.5 mm) | 29°/5.2 in. (131.5 mm)     | 29°/5.2 in. (131.5 mm)    |

## SPECIFICATIONS

### WEIGHT

|  | <b>CHIEF MODELS</b>                               | <b>CHIEF BOBBER MODELS</b>                        | <b>SUPER CHIEF MODELS</b>                         |
|--|---|---|---|
| Dry Weight (without fuel/fluids)                   | 647 lbs. (294 kg)                                 | 670 lbs (304 kg)                                  | 714 lbs (324 kg)                                  |
| Wet Weight (with fuel/fluids)                      | 670 lbs. (304 kg)                                 | 694 lbs. (315 kg)                                 | 739lbs. (335 kg)                                  |
| Gross Vehicle Weight Rating (GVWR)                 | 1160 lbs. (526 kg)                                | 1160 lbs. (526 kg)                                | 1160 lbs. (526 kg)                                |
| Gross Axle Weight Rating (GAWR)                    | Front 425 lbs. (193 kg)<br>Rear 739 lbs. (335 kg) | Front 425 lbs. (193 kg)<br>Rear 739 lbs. (335 kg) | Front 425 lbs. (193 kg)<br>Rear 739 lbs. (335 kg) |
| Maximum Load Capacity (riders, cargo, accessories) | 490 lbs. (222 kg)                                 | 466 lbs (211 kg)                                  | 421 lbs (191 kg)                                  |

### CAPACITIES

|                              | <b>ALL MODELS</b>                        |
|------------------------------|--|
| Engine Oil                   | 6 qts. (5.7 l) with filter at oil change |
| Fuel                         | 4.3 gal. (16.1 l)                        |
| Fuel Reserve (fuel light on) | 0.6 gal. (2.3 l)                         |
| Fork Oil                     | 18.8 oz. (557 cc)                        |

**ENGINE**

**THUNDER STROKE 111**

|                                | <b>THUNDER STROKE 111</b>                |
|--------------------------------|--|
| Engine Type                    | Thunder Stroke 111, Air Cooled           |
| Configuration                  | V-Twin                                   |
| Displacement                   | 111 cu. in. (1811 cc)                    |
| Cooling System                 | Air Cooled                               |
| Compression Ratio              | 9.5:1                                    |
| Valve Train                    | 2 Valves Per Cylinder, Hydraulic Lifters |
| Bore and Stroke                | 3.976" x 4.449" (101mm x 113mm)          |
| Fuel System/Throttle Body Bore | Closed Loop Fuel Injection/54 mm         |
| Exhaust System                 | Dual Exhaust w/<br>Collector at Catalyst |
| Rev Limit                      | 5400 RPM                                 |
| Idle RPM                       | 800 +/- 50 RPM Fully Warm                |
| Lubrication System             | Semi-Dry Sump                            |
| Spark Plug/Gap                 | NGK® DCPR8E/.034 inch (0.9 mm)           |

**THUNDER STROKE 116**

|                   | <b>THUNDER STROKE 116</b>                |
|-------------------|--|
| Engine Type       | Thunder Stroke 116, Air Cooled           |
| Configuration     | V-Twin                                   |
| Displacement      | 115 cu. in. (1890 cc)                    |
| Cooling System    | Air Cooled                               |
| Compression Ratio | 11.0:1                                   |
| Valve Train       | 2 Valves Per Cylinder, Hydraulic Lifters |
| Bore and Stroke   | 4.063" x 4.449" (103.2 mm x 113 mm)      |

## SPECIFICATIONS

|                                | <b>THUNDER STROKE 116</b>                |
|--------------------------------|--|
| Fuel System/Throttle Body Bore | Closed Loop Fuel Injection/54 mm         |
| Exhaust System                 | Dual Exhaust w/<br>Collector at Catalyst |
| Rev Limit                      | 5400 RPM                                 |
| Idle RPM                       | 900 +/- 50 RPM Fully Warm                |
| Lubrication System             | Semi-Dry Sump                            |
| Spark Plug/Gap                 | NGK® DCPR8E/.034 inch (0.9 mm)           |

## DRIVE SYSTEM

|                         | <b>ALL MODELS</b>                |
|-------------------------|----------------------------------|
| Primary Drive           | Gear Drive Wet Clutch            |
| Crank Gear              | 55 Teeth                         |
| Clutch Gear             | 86 Teeth                         |
| Clutch Type             | Wet, Multi-Plate                 |
| Primary Reduction Ratio | 1.564:1                          |
| Transmission Type       | 6 Speed/Constant Mesh/Foot Shift |
| 1st Gear Ratio          | 2.733:1                          |
| 2nd Gear Ratio          | 1.864:1                          |
| 3rd Gear Ratio          | 1.385:1                          |
| 4th Gear Ratio          | 1.103:1                          |
| 5th Gear Ratio          | 0.943:1                          |
| 6th Gear Ratio          | 0.811:1                          |
| Gear Shift Pattern      | 1 Down/5 Up                      |
| Final Drive Type        | Belt Drive, 146-Tooth            |
| Transmission            | 30-Tooth                         |
| Rear Wheel              | 66-Tooth                         |
| Ratio                   | 2.2:1                            |

|                           | <b>ALL MODELS</b> |
|---------------------------|-------------------|
| <b>Overall Gear Ratio</b> |                   |
| 1st Gear                  | 9.403:1           |
| 2nd Gear                  | 6.411:1           |
| 3rd Gear                  | 4.763:1           |
| 4th Gear                  | 3.796:1           |
| 5th Gear                  | 3.243:1           |
| 6th Gear                  | 2.789:1           |

**CHASSIS**

|                              | <b>ALL MODELS</b>                      |
|------------------------------|--|
| Front Suspension Type/Travel | Telescopic Fork/5.2 in. (132 mm)       |
| Front Fork Tube Diameter     | 46 mm                                  |
| Rear Suspension Type/Travel  | Dual Shocks/3.0 in. (75 mm)            |
| Swing-arm                    | Steel Welded                           |
| Front Brakes                 | Single/4 Piston Caliper/Floating Rotor |
| Rear Brakes                  | Single/2 Piston Caliper/Floating Rotor |

**SPECIFICATIONS**

---

**WHEELS AND TIRES**

|                       | <b>CHIEF MODELS</b>                 | <b>CHIEF BOBBER MODELS</b>          | <b>SUPER CHIEF MODELS</b>           |
|-----------------------|-------------------------------------|-------------------------------------|-------------------------------------|
| Front Wheel Size/Type | 3.5 in. x 19 in. Cast Aluminum      | 3 in. x 16 in. Spoked               | 3 in. x 16 in. Spoked               |
| Rear Wheel Size/Type  | 5 in. x 16 in. Cast Aluminum        | 5 in. x 16 in. Spoked               | 5 in. x 16 in. Spoked               |
| Front Tire Type/Size  | 130/60B19 61H Pirelli® Night Dragon | 130/90B19 67H Pirelli® Night Dragon | 130/90B19 67H Pirelli® Night Dragon |
| Rear Tire Type/Size   | 180/65B16 81H Pirelli® Night Dragon | 180/65B16 81H Pirelli® Night Dragon | 180/65B16 81H Pirelli® Night Dragon |

**ELECTRICAL**

|                    | <b>ALL MODELS</b>  |
|--------------------|--|
| Alternator         | 710W @ 3500 RPM  |
| Battery            | 12 Volt, 18 amp/hour, 310 CCA, Sealed Glass Mat                                |
| Power Points       | Front - 10 amp maximum<br>Rear - 10 amp maximum<br>(Combined - 10 amp maximum) |
| Voltage Regulator  | 14.5 volts/55 amp  |
| Headlight          | Non-Serviceable LED  |
| Auxiliary Light    | Non-Serviceable LED  |
| Tail/Brake Light   | Non-Serviceable LED  |
| Turn Signal        | Non-Serviceable LED  |
| License Plate      | Non-Serviceable LED  |
| Front Fender Light | Non-Serviceable LED  |
| Speedometer        | Non-Serviceable LED  |
| Indicator Lights   | Non-Serviceable LED  |





## FUEL RECOMMENDATION

For best performance, use only unleaded gasoline with a 91 pump octane minimum (R+M/2 Method) or 95 RON minimum. **DO NOT USE E-85 GASOLINE OR GASOLINE CONTAINING METHANOL.** Using E85 or gasoline/methanol blends can result in poor starting and driveability, engine damage and damage to critical fuel system components.

- *Gasoline containing up to 10% Ethanol can be used.*

In the event that the recommended premium unleaded gasoline is not available and low octane fuel must be used, fill the fuel tank only partially with unleaded regular gasoline, then fill the tank fully with premium unleaded gasoline as soon as possible.



## ENGINE OIL RECOMMENDATION

We recommend the use of INDIAN MOTORCYCLE Premium Synthetic Blend 20W-40 Engine Oil for your motorcycle. This oil is formulated with synthetic-based oil and premium engine additive which have physical properties that meet API SM and ILSAC GF-4 specifications.

Do not blend oil additives with engine oil.

If oil must be added in an emergency and the recommended oil is not available, choose only a high-quality 20W-40 motorcycle oil. Change back to the recommended oil at the first opportunity.

### NOTICE

Use of non-recommended lubricants can result in engine damage. Damage resulting from the use of non-recommended lubricants is not covered by warranty.

## FORK OIL

We recommend the use of INDIAN MOTORCYCLE Fork Oil for your motorcycle.

## BRAKE FLUID

We recommend the use of INDIAN MOTORCYCLE DOT 4 Brake Fluid for both brake master cylinders. **DO NOT use DOT 5 silicone fluid.**



## WARRANTY

### INDIAN MOTORCYCLE WARRANTY POLICY

#### LIMITED WARRANTY

INDIAN MOTORCYCLE, 2100 Highway 55, Medina, MN 55340 (INDIAN MOTORCYCLE) gives a TWO YEAR LIMITED WARRANTY on all components of your INDIAN MOTORCYCLE against defects in material or workmanship. This warranty covers parts and labor charges for repair or replacement of defective parts and begins on the date of purchase by the original retail purchaser. This warranty is transferable to another owner during the warranty period through an INDIAN MOTORCYCLE dealer, but any such transfer will not extend the original term of the warranty. The duration of this warranty may vary by international region based upon local laws and regulations.

#### REGISTRATION

At the time of sale, the Warranty Registration Form must be completed by your dealer and submitted to INDIAN MOTORCYCLE within ten days of purchase. Upon receipt of this registration, INDIAN MOTORCYCLE will record the registration for warranty. No verification of registration will be sent to the purchaser as the copy of the Warranty Registration Form will be your proof of warranty coverage. If you have not signed the original registration and received the customer copy, please contact your dealer immediately. **NO WARRANTY COVERAGE WILL BE ALLOWED UNLESS YOUR MOTORCYCLE IS REGISTERED WITH INDIAN MOTORCYCLE.** Initial dealer preparation and set-up of your motorcycle is very important in ensuring trouble-free operation. Purchasing a vehicle in the crate or without proper dealer set-up will void your warranty coverage.

#### WARRANTY DISCLAIMERS FOR RIDE COMMAND AND ASSOCIATED CONNECTED SERVICES

The Ride Command Terms & Conditions available at <https://ridecommand.indianmotorcycle.com>, including the Warranty Disclaimers therein, apply to Ride Command and associated connected services.

## WARRANTY

---

### LIMITATIONS OF WARRANTIES AND REMEDIES

This INDIAN MOTORCYCLE limited warranty excludes any failures that are not caused by a defect in material or workmanship. THIS WARRANTY DOES NOT COVER CLAIMS OF DEFECTIVE DESIGN. This warranty also does not cover acts of God, accidental damage, normal wear and tear, abuse or improper handling. This warranty also does not cover any motorcycle, component, or part that has been altered structurally, modified, neglected, improperly maintained or used for racing, competition, or purposes other than for which it was designed.

This warranty excludes damages or failures resulting from: improper lubrication; improper engine timing; improper fuel; surface imperfections caused by external stress, heat, cold or contamination; operator error or abuse; improper component alignment, tension, adjustment or altitude compensation; snow, water, dirt or other foreign substance ingestion/contamination; improper maintenance; modified components; use of aftermarket or unapproved components, accessories, or attachments; unauthorized repairs; or repairs made after the warranty period expires or by an unauthorized repair center.

This warranty excludes damages or failures caused by abuse, accident, fire, or any other cause other than a defect in materials or workmanship and provides no coverage for consumable components, general wear items, or any parts exposed to friction surfaces, stresses, environmental conditions and/or contamination for which they were not designed or not intended, including but not limited to the following items:

- Wheels and tires
- Suspension components
- Brake components
- Seat components
- Clutches and components
- Steering components
- Batteries
- Light bulbs/Sealed beam lamps
- Filters
- Lubricants
- Bushings
- Sealants
- Coolants
- Bearings
- Finished and unfinished surfaces
- Fuel Injectors/Throttle body components
- Engine components
- Drive belts
- Hydraulic components and fluids
- Circuit breakers/Fuses
- Electronic components
- Spark plugs

### **LUBRICANTS AND FLUIDS**

1. Mixing oil brands or using non-recommended oil may cause engine damage. We recommend the use of INDIAN MOTORCYCLE engine oil.
2. Damage or failure resulting from the use of non-recommended lubricants or fluids is not covered by this warranty.

This warranty provides no coverage for personal loss or expense, including mileage, transportation costs, hotels, meals, shipping or handling fees, motorcycle pick-up or delivery, replacement rentals, loss of vehicle use, loss of profits, or loss of vacation or personal time.

The exclusive remedy for breach of this warranty shall be, at INDIAN MOTORCYCLE's option, repair or replacement of any defective materials, components, or products. THE REMEDIES SET FORTH IN THIS WARRANTY ARE THE ONLY REMEDIES AVAILABLE TO ANY PERSON FOR BREACH OF THIS WARRANTY. INDIAN MOTORCYCLE SHALL HAVE NO LIABILITY TO ANY PERSON FOR INCIDENTAL, CONSEQUENTIAL OR SPECIAL DAMAGES OF ANY DESCRIPTION, WHETHER ARISING OUT OF EXPRESS OR IMPLIED WARRANTY OR ANY OTHER CONTRACT, NEGLIGENCE, OR OTHER TORT OR OTHERWISE. THIS EXCLUSION OF CONSEQUENTIAL, INCIDENTAL, AND SPECIAL DAMAGES IS INDEPENDENT FROM AND SHALL SURVIVE ANY FINDING THAT THE EXCLUSIVE REMEDY FAILED OF ITS ESSENTIAL PURPOSE.

THE IMPLIED WARRANTY OF FITNESS FOR A PARTICULAR PURPOSE IS EXCLUDED FROM THIS LIMITED WARRANTY. ALL OTHER IMPLIED WARRANTIES (INCLUDING BUT NOT LIMITED TO THE IMPLIED WARRANTY OF MERCHANTABILITY) ARE LIMITED IN DURATION TO THE ABOVE TWO YEAR WARRANTY PERIOD. INDIAN MOTORCYCLE DISCLAIMS ALL EXPRESS WARRANTIES NOT STATED IN THIS WARRANTY. SOME STATES DO NOT PERMIT THE EXCLUSION OR LIMITATION OF INCIDENTAL OR CONSEQUENTIAL DAMAGES OR ALLOW LIMITATIONS ON THE DURATION OF IMPLIED WARRANTIES, SO THE ABOVE LIMITATIONS MAY NOT APPLY TO YOU IF INCONSISTENT WITH CONTROLLING STATE LAW.

### **HOW TO OBTAIN WARRANTY SERVICE**

If your motorcycle requires warranty service, you must take it to an INDIAN MOTORCYCLE Servicing Dealer. When requesting warranty service you must present your copy of the Warranty Registration Form to the dealer. (THE COST OF TRANSPORTATION TO AND FROM THE DEALER IS YOUR RESPONSIBILITY). INDIAN MOTORCYCLE suggests that you use your original selling dealer; however, you may use any INDIAN MOTORCYCLE Servicing Dealer to perform warranty service.

## WARRANTY

---

### ***IN THE COUNTRY WHERE YOUR MOTORCYCLE WAS PURCHASED:***

Warranty or Service Bulletin repairs must be done by an authorized INDIAN MOTORCYCLE dealer. If you move or are traveling within the country where your motorcycle was purchased, Warranty and Service Bulletin repairs may be requested from any authorized INDIAN MOTORCYCLE dealer.

### ***OUTSIDE THE COUNTRY WHERE YOUR MOTORCYCLE WAS PURCHASED:***

If you are traveling temporarily outside the country where your motorcycle was purchased, you should take your motorcycle to an authorized INDIAN MOTORCYCLE dealer. You must show the dealer photo identification from the country of the selling dealer's authorized location as proof of residence. Upon residence verification, the servicing dealer will be authorized to perform the warranty repair.

### ***IF YOU MOVE:***

If you move to another country, be sure to contact INDIAN MOTORCYCLE Customer Assistance and the customs department of the destination country before you move. Vehicle importation rules vary considerably from country to country. You may be required to present documentation of your move to INDIAN MOTORCYCLE in order to continue your warranty coverage. You may also be required to obtain documentation from INDIAN MOTORCYCLE in order to register your motorcycle in your new country. You should warranty register your motorcycle at a local INDIAN MOTORCYCLE dealer in your new country immediately after you move to continue your warranty coverage and to ensure that you receive information and notices regarding your motorcycle.

### ***IF YOU PURCHASE FROM A PRIVATE PARTY:***

If you purchase an INDIAN MOTORCYCLE from a private party, to be kept and used outside of the country in which the motorcycle was originally purchased, all warranty coverage will be denied. You must nonetheless register your motorcycle under your name and address with a local INDIAN MOTORCYCLE dealer in your country to ensure that you receive safety information and notices regarding your motorcycle.

### EXPORTED VEHICLES

EXCEPT WHERE SPECIFICALLY REQUIRED BY LAW, THERE IS NO WARRANTY OR SERVICE BULLETIN COVERAGE ON THIS VEHICLE IF IT IS SOLD OUTSIDE THE COUNTRY OF THE SELLING DEALER'S AUTHORIZED LOCATION. This policy does not apply to vehicles that have received authorization for export from INDIAN MOTORCYCLE. Dealers may not give authorization for export. You should consult an authorized dealer to determine this vehicle's warranty or service coverage if you have any questions. This policy does not apply to vehicles registered to government officials or military personnel on assignment outside the country of the selling dealer's authorized location. This policy does not apply to Safety Bulletins.

### NOTICE

If your vehicle is registered outside of the country where it was purchased and you have not followed the procedure set above, your vehicle will no longer be eligible for warranty or service bulletin coverage of any kind, other than safety bulletins. Vehicles registered to Government officials or military personnel on assignment outside of the country where the vehicle was purchased will continue to be covered by the Limited Warranty.

Please work with your dealer to resolve any warranty issues. Should your dealer require any additional assistance, they will contact the appropriate person at INDIAN MOTORCYCLE.

This warranty gives you specific legal rights, and you may also have other rights which vary from state to state or in different countries. If any of the above terms are void because of federal, state, local law, all other warranty terms will remain in effect.

***For questions call INDIAN MOTORCYCLE Customer Assistance:***

United States & Canada: 1-877-204-3697

French: 1-800-268-6334

## WARRANTY

---

### MOTORCYCLE NOISE REGULATION

Tampering with noise control systems is prohibited. Federal law prohibits the following acts or causing thereof:

- The removal or rendering inoperative by any person other than for the purposes of maintenance, repair, or replacement, of any device or element of design incorporated into any new vehicle for the purpose of noise control prior to its sale or delivery to the ultimate purchaser or while it is in use, or
- The use of the vehicle after such device or element of design has been removed or rendered inoperative by any person.

Among those acts presumed to constitute tampering are:

- Removal or puncturing of the muffler, baffles, header pipes, or any other component which conducts exhaust gasses.
- Removal or puncturing of any part of the intake system.
- Lack of proper maintenance.
- Replacing any moving part of the vehicle, or parts of the exhaust system or intake system, with parts other than those specified by the manufacturer.

This product should be checked for repair or replacement if the motorcycle noise has increased significantly through use. Otherwise, the owner may become subject to penalties under state and local ordinances.

### NOISE EMISSION WARRANTY

INDIAN MOTORCYCLE warrants that this exhaust system, at the time of sale, meets all applicable U.S. EPA Federal noise standards. This warranty extends to the first person who buys this exhaust system for purposes other than resale, and to all subsequent buyers.

Warranty claims should be directed to:

- *An authorized INDIAN MOTORCYCLE dealer, or*
- *INDIAN MOTORCYCLE, 2100 Highway 55, Medina, MN 55340*



---

## **EMISSIONS CONTROL SYSTEM WARRANTY**

### **INDIAN MOTORCYCLE COMPANY - EMISSION CONTROL SYSTEM WARRANTY STATEMENT**

#### ***YOUR WARRANTY RIGHTS AND OBLIGATIONS***

The California Air Resources Board and INDIAN MOTORCYCLE are pleased to explain the emission control system warranty on your 2015 or later INDIAN MOTORCYCLE. In California, new motor vehicles must be designed, built and equipped to meet the state's stringent anti-smog standards. INDIAN MOTORCYCLE must warrant the emission control system on your motorcycle for the periods of time listed below provided there has been no abuse, neglect or improper maintenance of your motorcycle. Your emission control system may include parts such as the fuel-injection system, the ignition system, catalytic converter and engine computer. Also included may be hoses, belts, connectors and other emission related assemblies. Where a warrantable condition exists, INDIAN MOTORCYCLE will repair your motorcycle at no cost to you, including diagnosis, parts and labor.

#### ***MANUFACTURER'S WARRANTY COVERAGE***

Class III motorcycles (280cc and larger): for a period of use of five (5) years or 30,000 kilometers (18,641 miles), whichever first occurs.

If an emission-related part on your motorcycle is defective, the part will be repaired or replaced by INDIAN MOTORCYCLE. This is your emission control system DEFECTS WARRANTY.

#### ***MANUFACTURER'S WARRANTY COVERAGE (KOREA)***

Class III motorcycles (280cc and larger): for a period of use of two (2) years or 35,000 kilometers (21,747 miles), whichever first occurs.

If an emission-related part on your motorcycle is defective, the part will be repaired or replaced by INDIAN MOTORCYCLE. This is your emission control system DEFECTS WARRANTY.

## WARRANTY

---

### **OWNER'S WARRANTY RESPONSIBILITIES**

As the motorcycle owner, you are responsible for the performance of the required maintenance listed in your Rider's manual. INDIAN MOTORCYCLE recommends that you retain all receipts covering maintenance on your motorcycle, but INDIAN MOTORCYCLE cannot deny warranty solely for the lack of receipts or for your failure to ensure the performance of all scheduled maintenance. You are responsible for presenting your motorcycle to an INDIAN MOTORCYCLE dealer as soon as a problem exists. The warranty repairs should be completed in a reasonable amount of time, not to exceed 30 days. As the motorcycle owner, you should be aware that INDIAN MOTORCYCLE may deny your warranty coverage if your motorcycle or part has failed due to abuse, neglect, improper maintenance or unapproved modifications.

If you have any questions regarding your warranty rights and responsibilities, you should contact INDIAN MOTORCYCLE, 2100 Highway 55, Medina, MN 55340, or the California Air Resources Board, P.O. Box 8001, 9528 Telstar Avenue, El Monte, CA 91734-8001.

INDIAN MOTORCYCLE warrants that each new 2015 and later INDIAN MOTORCYCLE that includes as standard equipment a headlight, taillight and stoplight, and is street legal:

- A. is designed, built and equipped so as to conform at the time of initial retail purchases with all applicable regulations of the United States Environmental Protection Agency, and the California Air Resources Board; and
- B. is free from defects in material and workmanship which cause such motorcycle to fail to conform with applicable regulations of the United States Environmental Protection Agency or the California Air Resources Board for a period of use, depending on the engine displacement, of 12,000 kilometers (7,456 miles), if the motorcycle's engine displacement is less than 170 cubic centimeters; of 18,000 kilometers (11,185 miles), if the motorcycle's engine displacement is equal or greater than 170 cubic centimeters but less than 280 cubic centimeters; or of 30,000 kilometers (18,641 miles), if the motorcycle's engine displacement is 280 cubic centimeters or greater; or 5 (five) years from the date of initial retail delivery, whichever occurs first.

### **I. COVERAGE**

Warranty defects shall be remedied during customary business hours at any authorized INDIAN MOTORCYCLE dealer located within the United States of America in compliance with the Clean Air Act and applicable regulations of the United States Environmental Protection Agency and the California Air Resources Board. Any part or parts replaced under this warranty shall become the property of INDIAN MOTORCYCLE.

In the State of California only, emission-related warranted parts are specifically defined by the state's Emission Warranty Parts List. These warranted parts are: carburetor and internal parts; intake manifold; fuel tank; fuel injection system; spark advance mechanism; crankcase breather; air cutoff valves; fuel tank cap for evaporative emission controlled vehicles; oil filler cap; pressure control valve; fuel/vapor separator; canister; igniters; breaker governors; ignition coils; ignition wires; ignition points; condensers, and spark plugs if failure occurs prior to the first scheduled replacement; and hoses, clamps, fittings and tubing used directly in these parts. Since emission related parts may vary from model to model, certain models may not contain all of these parts and certain models may contain functionally equivalent parts. In the State of California only, Emission Control System emergency repairs, as provided for in the California Administrative Code, may be performed by other than an authorized INDIAN MOTORCYCLE dealer. An emergency situation occurs when an authorized INDIAN MOTORCYCLE dealer is not reasonably available, a part is not available within 30 days or a repair is not complete within 30 days. Any replacement part can be used in an emergency repair. INDIAN MOTORCYCLE will reimburse the owner for expenses, including diagnosis, not to exceed INDIAN MOTORCYCLE's suggested retail price for all warranted parts replaced and labor charges based on INDIAN MOTORCYCLE'S recommended time allowance for the warranty repair and the geographically appropriate hourly labor rate. The owner may be required to keep receipts and failed parts in order to receive compensation.

## WARRANTY

---

### **II. LIMITATIONS**

The Emission Control System Warranty shall not cover any of the following:

A. Repair or replacement required as a result of:

- Accident
- Misuse
- Repairs improperly performed or replacements improperly installed
- Use of replacement parts or accessories not conforming to INDIAN MOTORCYCLE specifications which adversely affect performance and/or
- Use in competitive racing or related events.

B. Inspections, replacement of parts, and other services and adjustments necessary for required maintenance

C. Any motorcycle on which the odometer mileage has been changed so that actual mileage cannot be readily determined.

### **III. LIMITED LIABILITY**

- A. The liability of INDIAN MOTORCYCLE under this Emission Control System Warranty is limited solely to the remedying of defects in material or workmanship by an authorized INDIAN MOTORCYCLE dealer at its place of business during customary business hours. This warranty does not cover inconvenience or loss of use of the motorcycle or transportation of the motorcycle to or from the INDIAN MOTORCYCLE dealer. INDIAN MOTORCYCLE SHALL NOT BE LIABLE FOR ANY OTHER EXPENSES, LOSS OR DAMAGE, WHETHER DIRECT, INCIDENTAL, CONSEQUENTIAL OR EXEMPLARY ARISING IN CONNECTION WITH THE SALE OR USE OF OR INABILITY TO USE THE INDIAN MOTORCYCLE FOR ANY PURPOSE. SOME STATES DO NOT ALLOW THE EXCLUSION OR LIMITATION OF ANY INCIDENTAL OR CONSEQUENTIAL DAMAGES, SO THE ABOVE LIMITATIONS MAY NOT APPLY TO YOU.
- B. NO EXPRESS EMISSION CONTROL SYSTEM WARRANTY IS GIVEN BY INDIAN MOTORCYCLE EXCEPT AS SPECIFICALLY SET FORTH HEREIN. ANY EMISSION CONTROL SYSTEM WARRANTY IMPLIED BY LAW, INCLUDING ANY WARRANTY OF MERCHANTABILITY OR FITNESS FOR A PARTICULAR PURPOSE, IS LIMITED TO THE EXPRESS EMISSION CONTROL SYSTEM WARRANTY TERMS STATED IN THIS WARRANTY. THE FOREGOING STATEMENTS OF WARRANTY ARE EXCLUSIVE AND IN LIEU OF ALL OTHER REMEDIES. SOME STATES DO NOT ALLOW LIMITATIONS ON HOW LONG AN IMPLIED WARRANTY LASTS SO THE ABOVE LIMITATIONS MAY NOT APPLY TO YOU.
- C. No dealer is authorized to modify this INDIAN MOTORCYCLE Limited Emission Control System Warranty.

### **IV. LEGAL RIGHTS**

THIS WARRANTY GIVES YOU SPECIFIC LEGAL RIGHTS, AND YOU MAY ALSO HAVE OTHER RIGHTS WHICH VARY FROM STATE TO STATE.

## WARRANTY

---

### ***V. THIS WARRANTY IS IN ADDITION TO THE INDIAN MOTORCYCLE LIMITED MOTORCYCLE WARRANTY***

### ***VI. ADDITIONAL INFORMATION***

Any replacement part that is equivalent in performance and durability may be used in the performance of any maintenance or repairs. However, INDIAN MOTORCYCLE is not liable for these parts. The owner is responsible for the performance of all required maintenance. Such maintenance may be performed at a service establishment or by any individual. The warranty period begins on the date the motorcycle is delivered to an ultimate purchaser.

INDIAN MOTORCYCLE

2100 Highway 55

Medina, MN 55340

ATTN: Warranty Department







**A**

About the Rider's Manual ..... 9

Accelerating ..... 78

Accessories  
Use ..... 14

AGM Battery Charger  
Recommendations ..... 148

AGM Battery Charging  
Recommendations – Deeply  
Discharged (Below 3 Volts) ..... 149

AGM Battery Charging  
Recommendations – Low Charge ..... 148

AGM Battery Charging  
Recommendations Table ..... 149

AGM Battery Maintenance Tips ..... 150

Anti-Lock Brake System (ABS) ..... 42

Anti-Lock Brake System Response ..... 15

App Tray ..... 53

Audio Control Switch ..... 27

Average Fuel Economy ..... 33

**B**

Battery ..... 137

Battery Care, Storage ..... 164

Battery Charging ..... 147

Battery Charging and Maintenance ..... 148

Battery Installation ..... 142

Battery Removal ..... 138

Battery Voltage ..... 33

Before You Ride ..... 46

Belt  
Adjustment ..... 113  
Alignment ..... 113

Bike Information ..... 50

Bluetooth® Pairing ..... 57

Brake Disc Inspection/Cleaning ..... 126

Brake Fluid ..... 175

Brake Fluid Precautions ..... 123

Brake Hoses/Connections ..... 122

Brake Light Replacement ..... 137

Brake Pads ..... 126

Brakes ..... 41  
Front Brake Lever ..... 43  
Rear Brake Pedal ..... 43

Braking ..... 77

Break-In Maintenance ..... 84

**C**

Capacities ..... 168

Care and Maintenance ..... 46

Carrying a Passenger ..... 12

Carrying Cargo ..... 13

Changing Your Security System PIN ..... 153

Changing Your Security System PIN,  
Premium Models ..... 154

Chassis ..... 171

Clean and Protect the Motorcycle ..... 164

Cleaning Products ..... 161

Clock ..... 35

Clutch Lever ..... 38

Console  
Cruiser Models ..... 21

Controls ..... 52

Crankcase Breather Hoses ..... 119

Cruise Control ..... 79  
Accelerate ..... 80  
Cruise Control Tips ..... 79  
Cruise Control, Cancel ..... 80  
Decelerate ..... 80  
Resume Speed ..... 80  
Set Speed ..... 80

Cruise Control Switch ..... 25

Cylinder Deactivation ..... 36

**D**

Diagnostic Functionality ..... 36

Dimensions ..... 167

Display Screens ..... 48

Display Units (Standard/Metric) ..... 34

Drive Belt  
Adjustment ..... 113  
Alignment ..... 113

Drive System ..... 170

**E**

Electrical ..... 173

Electrical Precautions ..... 151

# INDEX

---

|   |     |
|---|-----|
| Electromagnetic Interference.....           | 17  |
| Elevating the Motorcycle.....               | 157 |
| Engine .....                                | 169 |
| Engine Break-In.....                        | 71  |
| Engine Compression Test.....                | 154 |
| Engine Error Codes.....                     | 35  |
| Engine Identification Number .....          | 8   |
| Engine Oil Level .....                      | 63  |
| Engine Oil Recommendation .....             | 175 |
| Engine Oil/Filter Change .....              | 108 |
| Engine Protection.....                      | 164 |
| Engine Run Switch.....                      | 25  |
| Engine Speed.....                           | 32  |
| Engine Stop Switch.....                     | 25  |
| Evaporative Emission Control<br>System..... | 119 |
| Exhaust System Inspection .....             | 154 |

## F

|                                  |     |
|----------------------------------|-----|
| Fastener Inspection .....        | 157 |
| Fastener Torques .....           | 157 |
| Fork Oil .....                   | 175 |
| Front Brake Fluid.....           | 125 |
| Front Brake Lever .....          | 124 |
| Front Brake Pad Inspection ..... | 127 |
| Front Fork Inspection .....      | 118 |
| Front Wheel Installation .....   | 128 |
| Fuel and Exhaust Safety .....    | 15  |
| Fuel Cap.....                    | 44  |
| Fuel Filter .....                | 109 |

|  |     |
|--|-----|
| Fuel Gauge .....                             | 32  |
| Fuel Level<br>Chief Classic Dark Horse ..... | 71  |
| Fuel Recommendation .....                    | 175 |
| Fuel Stabilizer .....                        | 164 |
| Fuel System Components .....                 | 120 |
| Fueling.....                                 | 72  |
| Fuse Replacement.....                        | 150 |

## G

|                                    |     |
|------------------------------------|-----|
| Gauge Screen.....                  | 49  |
| Gear Indicator .....               | 32  |
| Gear Shift Lever.....              | 38  |
| Gloss Clear Coat Finish Care ..... | 162 |
| Gross Vehicle Weight Rating.....   | 19  |
| GVWR.....                          | 19  |

## H

|                                   |     |
|-----------------------------------|-----|
| Handlebar Position.....           | 132 |
| Headlight<br>Aim Inspection ..... | 135 |
| Headlight Aim Adjustment.....     | 136 |
| Headlight Beam Switch .....       | 26  |
| Headlight Lamp Replacement .....  | 137 |
| Headlights .....                  | 37  |
| High-Current Fuses .....          | 151 |

## I

|                                    |            |
|------------------------------------|------------|
| Identification Number Records..... | 7          |
| Idle Shut Down .....               | 75         |
| Indicator Lamps .....              | 29         |
| Infotainment Care .....            | 163        |
| Instantaneous Fuel Economy.....    | 33         |
| Instrument Cluster .....           | 29, 31, 33 |
| Speedometer .....                  | 31         |

## K

|                        |    |
|------------------------|----|
| Keyless Ignition ..... | 28 |
|------------------------|----|

## L

|                             |     |
|-----------------------------|-----|
| LUBRICANTS AND FLUIDS ..... | 179 |
|-----------------------------|-----|

## M

|   |     |
|---|-----|
| Maintenance During Storage.....             | 164 |
| Maintenance Intervals.....                  | 85  |
| Maintenance Log .....                       | 189 |
| Maintenance, Major.....                     | 84  |
| Maps and Navigation .....                   | 51  |
| Matte Clear Coat Finish Care .....          | 162 |
| Mechanical Clutch Cable<br>Lubrication..... | 122 |
| Mechanical Clutch Lever Freeplay .....      | 121 |

Mechanical Clutch Lever Lubrication ... 121  
 Media Switch..... 54  
 Mirrors..... 41  
 Misfire Detection..... 36  
 Modifications ..... 15  
 Motorcycle Noise Regulation ..... 182  
 Multi-Function Display (MFD)..... 32  
 Music ..... 52

**N**

Noise Emission Warranty..... 182

**O**

Odometer ..... 32  
 Operating Motorcycle Abroad ..... 8  
 Operating Speeds and Gears ..... 72  
 Outside Temperature..... 33

**P**

Parking ..... 80  
 Parking on a Slope ..... 81  
 Parking on a Soft Surface ..... 81  
 Parking the Motorcycle ..... 15  
 Periodic Maintenance ..... 84  
     Severe Use Definition..... 84

Pre-Ride Inspections..... 61  
     Brake Lines ..... 67  
     Electrical Inspections ..... 61  
     Fasteners ..... 68  
     Front Brake Fluid Level ..... 65  
     Front Brake Lever, Inspection..... 66  
     Front Suspension ..... 68  
     Fuel Level ..... 69  
     General Inspections ..... 62  
     Mechanical Clutch ..... 68  
     Rear Brake Fluid Level ..... 66  
     Rear Brake Pedal, Inspection..... 66  
     Rear Drive Belt ..... 69  
     Side-stand ..... 67  
     Steering ..... 69  
     Throttle ..... 67  
     Tire Condition ..... 65  
     Tire Pressure ..... 64  
     Tire Tread Depth..... 65  
     Tires ..... 64  
 Priming the Fuel System..... 73  
 Protective Apparel ..... 12

**R**

Radio Compliance Statements..... 17  
 Rear Brake Fluid ..... 123  
 Rear Brake Pad Inspection ..... 127  
 Rear Brake Pedal..... 122  
 Rear Drive Belt Cleaning ..... 111  
 Rear Drive Belt Condition..... 111

Rear Drive Belt Wear Analysis ..... 111  
 Rear Shock Preload Inspection ..... 116  
 Removal From Storage ..... 165  
 Reporting Safety Defects ..... 19  
 Reporting Safety Defects (Canada) ..... 19  
 Ride Command..... 45  
     Buttons ..... 47  
     Icon Bar ..... 48  
     Overview..... 47  
     Update Software..... 58  
 Ride Command Display  
     Over the Air Updates..... 58  
 Ride Height Inspection..... 116  
 Ride Information ..... 51  
 Ride Modes..... 33, 55  
 Road Test..... 157  
 Road Tests ..... 84  
 Rodents ..... 164

**S**

Saddlebags..... 39  
     Soft Bag Removal ..... 39  
 Saddlebags, Trunk and Other Storage... 13  
 Safe Riding Practices ..... 9  
     Follow These General Safe Riding  
         Practices ..... 10  
     Motorcycling Has Inherent Risks..... 9  
 Safety and Information Labels ..... 20  
 Safety During Service Procedures..... 83

# INDEX

---

|                                       |                   |
|---------------------------------------|-------------------|
| Safety Maintenance .....              | 16                |
| Safety Symbols .....                  | 4                 |
| Seat Installation .....               | 135               |
| Seat Removal .....                    | 134               |
| Security System .....                 | 152-154           |
| Select Switch .....                   | 54                |
| Service Information .....             | 8                 |
| Service Intervals                     |                   |
| Maintenance .....                     | 85                |
| Settings .....                        | 56                |
| Shifting Gears.....                   | 75                |
| Recommended Shift Points .....        | 77                |
| Shifting Gears While Driving .....    | 76                |
| Shifting Gears While Stationary ..... | 75                |
| Sidestand.....                        | 40                |
| Sidestand Lubrication .....           | 120               |
| Signal Words .....                    | 4                 |
| Spark Plugs.....                      | 133               |
| Specifications .....                  | 167-171, 173, 175 |
| Standard Fuses .....                  | 150               |
| Starting the Engine.....              | 73                |
| Steering Head Inspection .....        | 118               |
| Stopping the Engine .....             | 78                |
| Storage Area Preparation .....        | 163               |
| Storage, Park and Cover.....          | 165               |
| Suspension Inspection .....           | 118               |
| Swing Arm/Rear Axle Inspection .....  | 117               |
| Switch Locations                      |                   |
| Left Control .....                    | 22                |
| Right Control.....                    | 22                |
| Switches .....                        | 22-23, 25-27      |
| Hazard Switch.....                    | 27                |

|                     |    |
|---------------------|----|
| Horn Switch .....   | 26 |
| Power Switch.....   | 24 |
| Switch Symbols..... | 23 |

## T

|                                       |         |
|---------------------------------------|---------|
| Tachometer.....                       | 31      |
| Taillight Replacement .....           | 137     |
| Throttle Control Grip .....           | 37      |
| Throttle Control Inspection .....     | 120     |
| Tire Condition .....                  | 129     |
| Tire Inflation.....                   | 164     |
| Tire Pressure .....                   | 130     |
| Tire Pressure Chart .....             | 130     |
| Tire Pressure Monitoring System ..... | 39      |
| Tire Replacement.....                 | 128     |
| Tire Tread Depth.....                 | 129     |
| Tires .....                           | 64, 128 |
| Toggle Switches.....                  | 23      |
| Transporting the Motorcycle.....      | 16      |
| Trigger Switches.....                 | 55      |
| Trip Odometer .....                   | 32      |
| Troubleshooting .....                 | 158-160 |

## U

|                  |    |
|------------------|----|
| Update Maps..... | 59 |
| USB Port .....   | 60 |

## W

|                             |         |
|-----------------------------|---------|
| Warning Symbols.....        | 4       |
| Warranty .....              | 177     |
| Warranty Information.....   | 8       |
| Washing the Motorcycle..... | 161     |
| Weight .....                | 168     |
| Wheel Alignment .....       | 127     |
| Wheel Inspection .....      | 127     |
| Wheel Spokes .....          | 127     |
| Wheels And Tires.....       | 173     |
| Windshield Care.....        | 41, 162 |
| Windshield Removal.....     | 41      |



To locate your nearest dealer,  
visit [www.indianmotorcycle.com](http://www.indianmotorcycle.com)

**INDIAN MOTORCYCLE**

2100 Highway 55

Medina, MN 55340

Phone: 1-877-204-3697

French: 1-800-268-6334



**Part No. 9939939 Rev 02**  
**Printed in U.S.A.**

